

PRODUCT NEWS

No. 397改

シリーズ拡張
SERIES EXPANSION

DIJET

重切削用刃先交換式ボールエンドミル

Swing Ball

Indexable Ball Nose End Mill

series

スウィングボール シリーズ SWB形

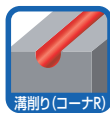
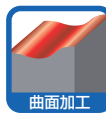

重切削
極めれば
SWB



NEW **G-Body** シリーズ

NEW 小径サイズφ16mmエンドミルタイプ
およびモジュラータイプ



ダイジェット工業株式会社



特長 Features

生材から肉盛り材まで用途に応じた最適チップをラインナップ。高能率・長寿命化。
The most suitable inserts from raw material to welding material. For high efficiency and longer tool life.

1. 切削音が静かで、切削抵抗が低く、高速高送りが可能。

ポジ刃形、プレーカの採用と、チップに設けた幅広ニックにより切削抵抗を当社従来品に比べ25%低減!

Smooth and calm cutting and low cutting forces at higher feed rates.

Cutting forces reduced by 25% compared with conventional type. This is achieved by use of a positive style insert with chipbreaker groove and edge notches. Double insert design gives the cutter a smooth cutting action and excellent production.

2. 先端部の耐欠損性が高く、突込み切削が可能。

先端渦巻きR刃のスライ面上に副ポケットを設け、切りくず排出性および耐欠損性を改善。(高精度SWB-H形チップを除く)

Plunge cutting possible because of better crack-resistance on cutting nose portion.

By providing sub chip pocket at spiral nose R-portion to eject chips smoothly and improves crack-resistance (except for semi-finishing insert -H type).

3. 高いクランプ剛性およびチップ剛性。

鼓形キーの嵌合性を高めクランプ剛性を改善した。またチップ厚を厚くし、断面強度を当社従来品に比べ40%高めた。キー形状の変更とあわせ、従来品より2倍以上の強度アップを実現。

Reliable insert location and improved security for heavy operations.

Fitness of clamping key is improved to prevent insert movement during the cutting action and inserts thickness adapted giving increased impact strength for safe production.

4. ホルダ108種類は世界No.1。

既存の58種類に加え、ユーザー仕様をそのままラインナップ。シリーズを一気に拡大し、108種類に。

108 bodies variety is the best in the world.

Added 50 different types on existing 58 types for die and mold making specification. Extended Swing Ball series to 108 different types.

5. 本体耐久性に優れた G-Body シリーズもラインナップ。

耐熱性に優れた強靱性鋼+表面のGN処理により、表面硬さ65HRC以上と高硬度かつ熱変形に強く高剛性で、本体耐久性および工具寿命を従来品比30%以上アップ。過酷な加工条件にも威力を発揮します。さらに、切りくずの溶着、錆の発生を抑制する効果もあります。

Adopted GN surface-hardening treatment on thermal resistant high strength steel gives high hardness over 65HRC and secure insert pocket and holder against thermal deformation, improved body durability and tool life by 30% or more. Make it difficult to be damaged even under severe cutting conditions. Also rust-proof and anti-welding effect is much improved.

6. NEW 小径サイズφ16mmエンドミルタイプおよびモジュラータイプを新たにラインナップ。

高精度なR精度を採用し、荒加工のみならず中仕上げ領域での使用が可能。

NEW Available now 16mm end mill type & modular head type.

Improving nose radius accuracy can be possible from roughing to semi-finishing.

充実のチップバリエーション Inserts series expansion.

通常タイプに加え、①低抵抗形 ②肉盛り用 ③中仕上げ用の3タイプをラインナップ。用途に応じさまざまな加工に対応。

Available now 3 type Inserts suitable for various uses.

① 低抵抗形 (-N形) Insert for low cutting forces (-N type)

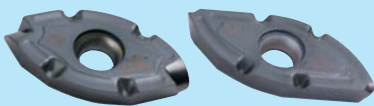

1. 切削抵抗を従来形と比較し15%低減! びりり低減、切削音もさらに静かなECO対応形
2. 寿命も従来形と比較し1.7倍
3. 新ニック形状の採用。配置・深さにも考慮し、高送りでも切りくずを分断させ、切りくず排出性を向上



1. 15% reduced cutting forces compared with regular type. More smooth and calm cutting are achieved.
2. Completely broke the chips and improved chip ejection by adopting new edge notches.

■ 切削性能 Cutting performance

● 切りくず形状 Chip formation

	ダウンカット Down cut		アップカット Up cut	
	主刃 Main blade	副刃 Sub blade	主刃 Main blade	副刃 Sub blade
SWB-N形 (低抵抗形) For low cutting forces (-N type) 切りくずが熱をもっていない				
SWB形 (従来品) Regular type 切りくずが熱をもっている				

高送りでもニック部で完全に分断されている
Completely breaking chips by notch.

ニック部の切りくずが分断されていない
Not completely breaking chips by notch.

● 切りくず形状の比較 Chip formation comparison

Chip formation comparison

本体: SWBS5060C508 (φ50)
Body

被削材: SKD11 (217HB)
Material 1.2379 (217HB)

切削条件: $n = 1,350 \text{ min}^{-1}$
Cutting condition $f = 0.6 \text{ mm/rev}$
 $a_e = 10 \text{ mm}$
 $a_p = 10 \text{ mm}$

●切削抵抗(合力)の比較 Cutting force comparison

被削材 Material : SKD11(217HB) 1.2379 (217HB)
 工具径 Tool dia. : $\phi 50\text{mm}$
 $n=1,082\text{min}^{-1}$, $V_c=170\text{m/min}$, $V_f=650\text{mm/min}$, $f=0.5\text{mm/rev}$
 $a_p=10\text{mm}$, $a_e=10\text{mm}$, ダウンカット Down cut

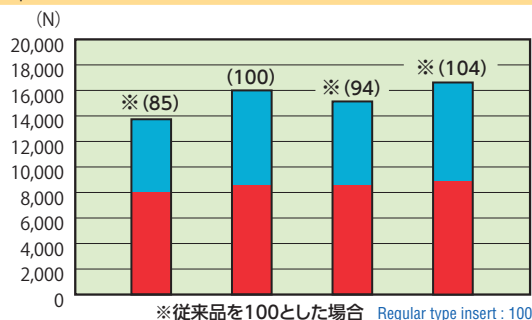

	低抵抗形 -N type	従来形 Regular type	A社 Competitor A	B社 Competitor B
副刃 Sub blade	5,890	7,525	6,454	7,783
主刃 Main blade	7,901	8,524	8,671	8,925

従来形に比べ15%ダウン

Compared with regular type insert, -N type insert (for low cutting forces) reduced 15% cutting force.

●SKD11寿命比較(φ50) Tool life comparison for 1.2379 (217HB)

被削材 Material : SKD11(217HB) 1.2379 (217HB)
 $n=1,350\text{min}^{-1}$, $V_c=212\text{m/min}$, $V_f=810\text{mm/min}$, $f=0.6\text{mm/rev}$
 $a_p=10\text{mm}$, $a_e=10\text{mm}$, ダウンカット&アップカット Down & Up cut
 エアブロー Air blow

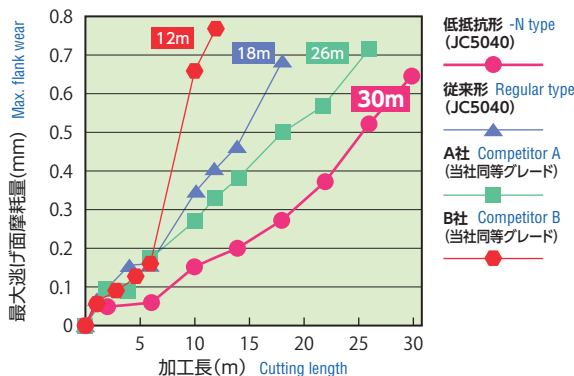

従来形に比べ1.6倍アップ

Compared with regular type insert, -N type insert (for low cutting forces) improved tool life by 1.6 times.

②肉盛り用 (-W形) Insert for welding & hardened steel (-W type)

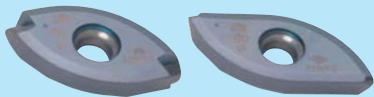

1. 刃先に強度を持たせ、専用材種を使用し高寿命
 2. 肉盛り加工および高硬度材 (50HRC~) にも対応し、非常に高寿命!
1. Improved insert strength and adopting new grade achieved longer tool life.
 2. Suitable for welding & hardened steel (over 50HRC).

③中仕上げ用 (主刃のみ -H形) Insert for semi-finishing (main blade -H type)

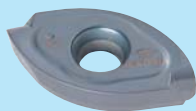

1. $\phi 20$ 、 $\phi 25$ 、 $\phi 30$ をラインナップ(副刃は、SWB2**HS (主刃と同一材種)を使用)
 2. 従来品に比べ渦巻き刃部のR精度をよくしたことにより、中仕上げへの使用が可能。
荒加工用としての使用は推奨しません。
1. Main blades -H type for semi-finishing are available for $\phi 20\text{mm}$, $\phi 25\text{mm}$ and $\phi 30\text{mm}$.
 Sub blades are use of regular inserts with same grade.
 2. Able to use for semi-finishing by improving nose radius accuracy.
 Do not recommend to use for roughing.

●従来チップとの違い Insert comparison

従来タイプ SWB-HM形
 Regular type insert

R min. 14.906
 R max. 14.981

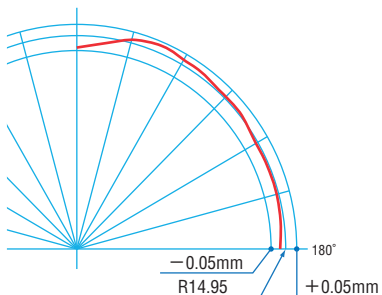

中仕上げ用 SWB-HM-H形
 Insert for semi-finishing

R min. 14.938
 R max. 14.983

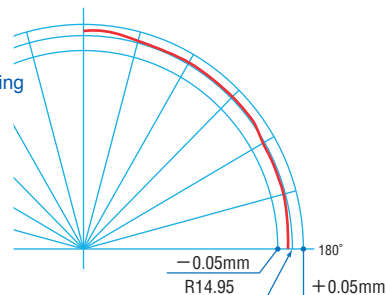

カッタ組込み時のR精度 Radius form accuracy on body

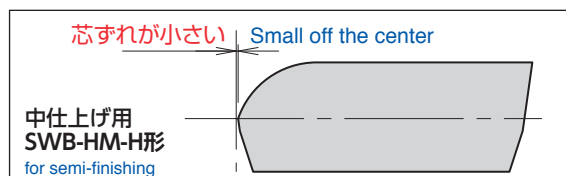
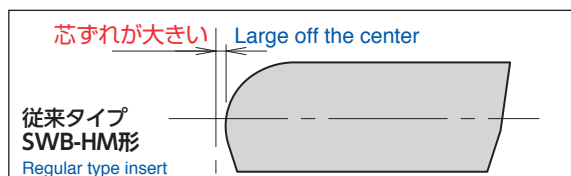

SWB形 ストレートシャンクタイプ・コンビネーションシャンクタイプ

"G-Body" series

G-Body シリーズ

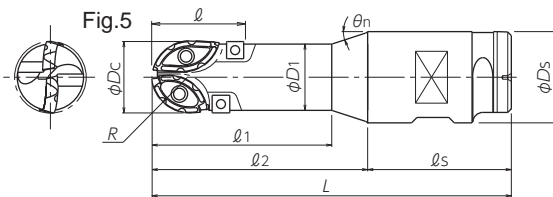
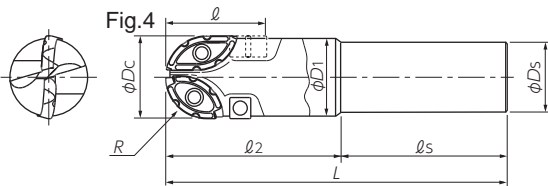
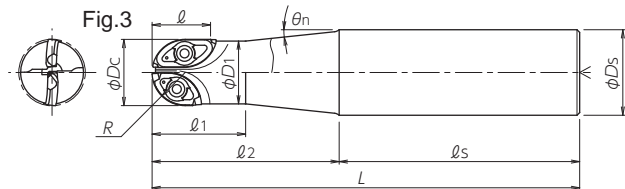
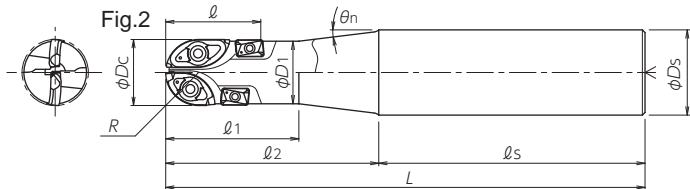
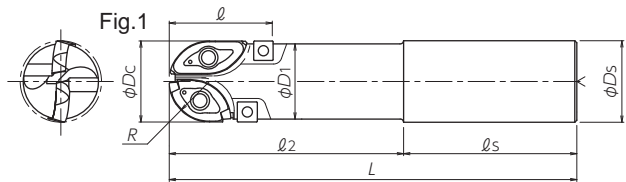

■本体 Body

シャンクタイプ Shank type	形番 Cat. No.	在庫 Stock	使用チップ数 No. of inserts			寸法(mm) Dimensions										Fig.	
			主刃 Main blade	副刃 Sub blade	外周刃 Peripheral blade	R	ϕDc	ℓ	ℓ_2	ℓ_s	L	ℓ_1	$\phi D1$	θ_n	ϕDs		Md
ストレート Straight	SWB-20080S-S20	●	1	1	2	10	20	30	80	80	160	—	18.7	—	20	—	1
	SWB-20120S-S20	●	1	1	2			30	120	80	200	—	18.7	—	20	—	1
	SWB-20170S-S20	●	1	1	2			30	170	80	250	—	18.7	—	20	—	1
	SWBS2030S25	●	1	1	2	12.5	25	30	80	100	180	40	18.7	3°30'	25	—	2
	SWBM2030S25	●	1	1	2			30	100	100	200	40	18.7	2°	25	—	2
	SWBS2018S25	●	1	1	—	15	30	18	70	90	160	30	18.7	3°30'	25	—	3
	SWB-25080S-S25	●	1	1	2			35	80	80	160	—	23.5	—	25	—	1
	SWB-25120S-S25	●	1	1	2	16	32	35	120	80	200	—	23.5	—	25	—	1
	SWB-25170S-S25	●	1	1	2			35	170	80	250	—	23.5	—	25	—	1
	SWBS2535S32	●	1	1	2			35	80	100	180	50	23.5	7°	32	—	2
SWBM2535S32	●	1	1	2	20	40	35	100	100	200	50	23.5	4°	32	—	2	
SWBS2522S32	●	1	1	—			22	70	90	160	35	23.5	6°	32	—	3	
SWB-30120S-S32	●	1	1	2			41	120	80	200	—	28.2	—	32	—	1	
SWB-30170S-S32	●	1	1	2	25	50	41	170	80	250	—	28.2	—	32	—	1	
SWB-30220S-S32	●	1	1	2			41	220	80	300	—	28.2	—	32	—	1	
SWBS3040S32	●	1	1	2			41	120	80	200	60	28.2	1°	32	—	2	
SWBM3040S32	●	1	1	2	20	40	41	150	100	250	60	28.2	0°40'	32	—	2	
SWBS3025S32	●	1	1	—			25	120	80	200	50	28.2	1°	32	—	3	
SWBS3242S32-G	●	1	1	2			16	32	44	60	120	180	—	29.9	—	32	—
SWBM3242S32-G	●	1	1	2	44	60			160	220	—	29.9	—	32	—	1	
SWBS4050S42	●	1	1	2	25	50	50	120	80	200	—	36.9	—	42	—	1	
SWBM4050S42	●	1	1	2			50	150	100	250	120	36.9	2°30'	42	—	2	
SWBS4035S42	●	1	1	—			35	120	80	200	—	36.9	—	42	—	3	
SWBS5060S42	●	1	1	2	20	40	60	100	100	200	—	46.8	—	42	—	4	
SWBM5060S42	●	1	1	2			60	100	150	250	—	46.8	—	42	—	4	
SWBS4050C508	●	1	1	2	25	50	50	120	80	200	100	36.9	18°	50.8	—	5	
SWBM4050C508	●	1	1	2			50	170	80	250	150	36.9	18°	50.8	—	5	
SWBS5060C508	●	1	1	2	25	50	60	120	80	200	—	46.8	—	50.8	—	5	
SWBM5060C508	●	1	1	2			60	170	80	250	—	46.8	—	50.8	—	5	

注) 1. 本体にチップは組込んでおりません。2. 溝加工時のフォーム誤差についてはP.25をご参照ください。

3. 用途により対応チップの組合せが異なります。チップの選定はP.4をご参照ください。

切削条件 Cutting conditions 22~27ページ

Note) 1. All cutters are supplied without inserts. 2. Please see page 25 for machined form error.

3. Please see page 4 for inserts combination.

Straight shank type / Combination shank type

■部品 Parts

対応ホルダ Applicable holders ϕD_c	クランプねじ Clamp Screw		レンチ Wrench		チップ Inserts		
	主刃・副刃用 For main & sub	外周刃用 For peripheral	主刃・副刃用 For main & sub	外周刃用 For peripheral	主刃 Main blade	副刃 Sub blade	外周刃 Peripheral blade
$\phi 20$	DSW-307H	ESW-206	A-10	A-08SD	SWB220HM	SWB220HS	ZCMT100308R
					SWB220HM-H (中仕上げ用) (For semi-finishing)	SWB220HS (必ず主刃と同一材種を選択のこと) (Be sure to choose the same grade as main blade)	
					SWB220MMW (肉盛り加工用) (For welding & hardened)	SWB220MSW (肉盛り加工用) (For welding & hardened)	
$\phi 25$	DSW-4085	ESW-206	A-15	A-08SD	SWB225HM	SWB225HS	ZCMT100308R
					SWB225HM-H (中仕上げ用) (For semi-finishing)	SWB225HS (必ず主刃と同一材種を選択のこと) (Be sure to choose the same grade as main blade)	
					SWB225MMW (肉盛り加工用) (For welding & hardened)	SWB225MSW (肉盛り加工用) (For welding & hardened)	
$\phi 30$	DSW-511H	CSW-407	A-20	A-15	SWB230HM	SWB230HS	IM-SP32GS
					SWB230HM-H (中仕上げ用) (For semi-finishing)	SWB230HS (必ず主刃と同一材種を選択のこと) (Be sure to choose the same grade as main blade)	
					SWB230MMW (肉盛り加工用) (For welding & hardened)	SWB230MSW (肉盛り加工用) (For welding & hardened)	
$\phi 32$	TSW-511	ESW-206	A-20	A-08SD	SWB232HM-G	SWB232HS-G	ZCMT100308R
					SWB232MMW-G (肉盛り加工用) (For welding & hardened)	SWB232MSW-G (肉盛り加工用) (For welding & hardened)	
$\phi 40$	TSW-614H	ESW-406	A-25	A-15	SWB240HMN	SWB240HSN	SPGA090304 SPMA090304
					SWB240MMW (肉盛り加工用) (For welding & hardened)	SWB240MSW (肉盛り加工用) (For welding & hardened)	
$\phi 50$	HSW-614H	CSW-510	A-30	A-20	SWB250HMN-N (低抵抗形) (For low cutting forces)	SWB250HSN-N (低抵抗形) (For low cutting forces)	IM-SP43GS
					SWB250MMW (肉盛り加工用) (For welding & hardened)	SWB250MSW (肉盛り加工用) (For welding & hardened)	

注) 1. $\phi 20$ 、 $\phi 25$ 、 $\phi 30$ 、 $\phi 40$ の外周刃なしタイプのホルダには、上記の外周刃および外周刃用ねじとレンチは不要です。

2. 中仕上げ用-H形主刃を使用時の副刃は、必ず主刃と同一材種を使用ください。
3. 低抵抗-N形は、必ず主刃と副刃セット(末尾-Nのセット)で使用ください。

Note) 1. No need to use peripheral inserts, clamp screw and wrench for no peripheral blade type body of $\phi 20$, $\phi 25$, $\phi 30$ and $\phi 40$.

2. In case of using main blade -H type for semi-finishing, be sure to use same grade for sub blade.
3. In case of using -N low cutting force inserts, be sure to use same notched inserts for main blade and sub blade together.

クランプねじ形番 Clamp screw	推奨トルク(N・m) Recommended torque
DSW-2563H	0.9
DSW-307H	1.8
DSW-4085	3.6
DSW-511H	6.1
TSW-511	5.5
TSW-614H	7.5
HSW-614H	7.5
ESW-206	0.9
CSW-407	3.6
ESW-406	3.1
CSW-510	5.5

SWB形 ストレートシャンクタイプ

Straight shank type

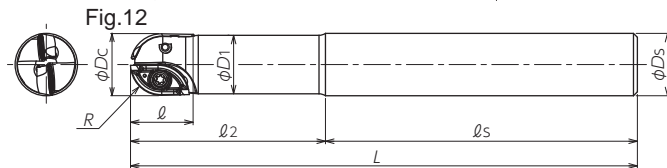
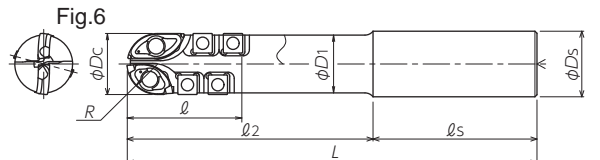
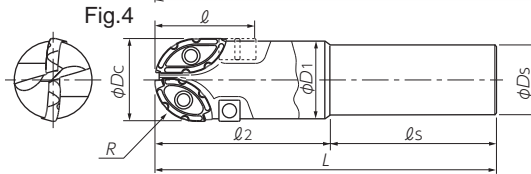
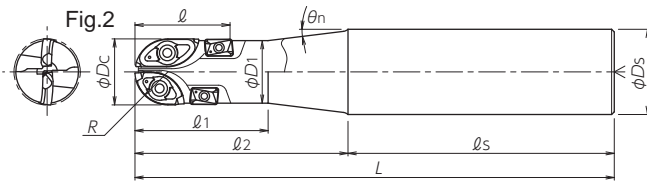
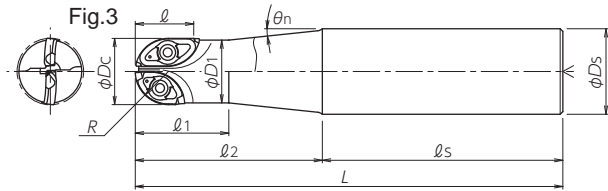

■本体 Body

シャンクタイプ Shank type	形番 Cat. No.	在庫 Stock	使用チップ数 No. of inserts			寸法(mm) Dimensions											Fig.
			主刃 Main blade	副刃 Sub blade	外周刃 Peripheral blade	R	φDc	ℓ	ℓ2	ℓs	L	ℓ1	φD1	θn	φDs	Md	
	NEW SWB-16050S-S16	●	1	1	—			15	50	80	130	—	15	—	16	—	12
	NEW SWBS1615S20	●	1	1	—	8	16	15	50	80	130	25.5	15	1°30'	20	—	3
	NEW SWBM1615S20	●	1	1	—			15	100	80	180	25.5	15	1°	20	—	3
	SWBL2030S25	●	1	1	2			30	100	150	250	40	18.7	2°	25	—	2
	SWBL2030S32	●	1	1	2			30	100	150	250	40	18.7	5°30'	32	—	2
	SWBE2030S32	●	1	1	2			30	110	190	300	40	18.7	4°30'	32	—	2
	SWBM2018S25	●	1	1	—	10	20	18	100	100	200	30	18.7	2°	25	—	3
	SWBL2018S25	●	1	1	—			18	110	140	250	30	18.7	1°30'	25	—	3
	SWBL2018S32	●	1	1	—			18	110	140	250	30	18.7	4°	32	—	3
	SWBE2018S32	●	1	1	—			18	120	180	300	30	18.7	3°30'	32	—	3
	SWBSS2535S25	●	1	1	2			35	70	80	150	—	23.5	—	25	—	2
	SWBML2535S25	●	1	1	2			35	70	150	220	—	23.5	—	25	—	2
	SWBL2535S32	●	1	1	2			35	110	140	250	50	23.5	3°30'	32	—	2
	SWBE2535S32	●	1	1	2	12.5	25	35	120	180	300	50	23.5	3°	32	—	2
ストレート Straight	SWBM2522S32	●	1	1	—			22	100	100	200	35	23.5	3°	32	—	3
	SWBL2522S32	●	1	1	—			22	110	140	250	35	23.5	2°40'	32	—	3
	SWBE2522S32	●	1	1	—			22	120	180	300	35	23.5	2°20'	32	—	3
	SWBSS3040S32	●	1	1	2			41	80	90	170	50	28.2	3°	32	—	2
	SWBL3040S32	●	1	1	2			41	200	100	300	60	28.2	0°30'	32	—	2
	SWBE3040S32	●	1	1	2			41	200	150	350	60	28.2	0°30'	32	—	2
	SWBSS3025S32	●	1	1	—	15	30	25	80	90	170	40	28.2	2°	32	—	3
	SWBM3025S32	●	1	1	—			25	170	80	250	50	28.2	0°40'	32	—	3
	SWBM3056S32	●	1	1	4			56	120	80	200	—	28.2	—	32	—	6
	SWBL3056S32	●	1	1	4			56	170	80	250	—	28.2	—	32	—	6
	SWBL3242S32-G	●	1	1	2	16	32	44	60	190	250	—	29.9	—	32	—	2
	SWBE3242S32-G	●	1	1	2			44	60	240	300	—	29.9	—	32	—	2
	SWBSS4050S42	●	1	1	2			50	80	80	160	—	36.9	—	42	—	2
	SWBL4050S42	●	1	1	2	20	40	50	200	100	300	150	36.9	1°30'	42	—	2
	SWBE4050S42	●	1	1	2			50	200	150	350	150	36.9	1°30'	42	—	2
	SWBM4035S42	●	1	1	—			35	170	80	250	120	36.9	2°	42	—	3
	SWBL5060S42	●	1	1	2	25	50	60	150	150	300	—	46.8	—	42	—	4
	SWBE5060S42	●	1	1	2			60	150	200	350	—	46.8	—	42	—	4

注) 1. 本体にチップは組込んでおりません。2. 溝加工時のフォーム誤差についてはP.25をご参照ください。



3. 用途により対応チップの組合せが異なります。チップの選定はP.6をご参照ください。

切削条件 Cutting conditions 22~27ページ

Note) 1. All cutters are supplied without inserts. 2. Please see page 25 for machined form error.

3. Please see page 6 for inserts combination.

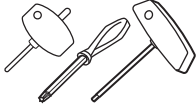
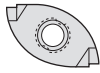
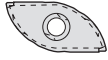
■部品 Parts

対応ホルダ Applicable holders φDc	クランプねじ Clamp Screw		レンチ Wrench		チップ Inserts		
	主刃・副刃用 For main & sub	外周刃用 For peripheral	主刃・副刃用 For main & sub	外周刃用 For peripheral	主刃 Main blade	副刃 Sub blade	外周刃 Peripheral blade
							
φ16	DSW-2563H	—	A-08SD	—	SWB216HM	SWB216HS	—
φ20	DSW-307H	ESW-206	A-10	A-08SD	SWB220HM	SWB220HS	ZCMT100308R
					SWB220HM-H (中仕上げ用) (For semi-finishing)	SWB220HS (必ず主刃と同一材種を選択のこと) (Be sure to choose the same grade as main blade)	
					SWB220MMW (肉盛り加工用) (For welding & hardened)	SWB220MSW (肉盛り加工用) (For welding & hardened)	
φ25	DSW-4085	ESW-206	A-15	A-08SD	SWB225HM	SWB225HS	ZCMT100308R
					SWB225HM-H (中仕上げ用) (For semi-finishing)	SWB225HS (必ず主刃と同一材種を選択のこと) (Be sure to choose the same grade as main blade)	
					SWB225MMW (肉盛り加工用) (For welding & hardened)	SWB225MSW (肉盛り加工用) (For welding & hardened)	
φ30	DSW-511H	CSW-407	A-20	A-15	SWB230HM	SWB230HS	IM-SP32GS
					SWB230HM-H (中仕上げ用) (For semi-finishing)	SWB230HS (必ず主刃と同一材種を選択のこと) (Be sure to choose the same grade as main blade)	
					SWB230MMW (肉盛り加工用) (For welding & hardened)	SWB230MSW (肉盛り加工用) (For welding & hardened)	
φ32	TSW-511	ESW-206	A-20	A-08SD	SWB232HM-G	SWB232HS-G	ZCMT100308R
					SWB232MMW-G (肉盛り加工用) (For welding & hardened)	SWB232MSW-G (肉盛り加工用) (For welding & hardened)	
φ40	TSW-614H	ESW-406	A-25	A-15	SWB240HMN	SWB240HSN	SPGA090304 SPMA090304
					SWB240MMW (肉盛り加工用) (For welding & hardened)	SWB240MSW (肉盛り加工用) (For welding & hardened)	
φ50	HSW-614H	CSW-510	A-30	A-20	SWB250HMN-N (低抵抗形) (For low cutting forces)	SWB250HSN-N (低抵抗形) (For low cutting forces)	IM-SP43GS
					SWB250MMW (肉盛り加工用) (For welding & hardened)	SWB250MSW (肉盛り加工用) (For welding & hardened)	

注) 1. φ20、φ25、φ30、φ40の外周刃なしタイプのホルダには、上記の外周刃および外周刃用ねじとレンチは不要です。
 2. 中仕上げ用-H形主刃を使用時の副刃は、必ず主刃と同一材種を使用ください。
 3. 低抵抗-N形は、必ず主刃と副刃セット(末尾-Nのセット)で使用ください。

Note) 1. No need to use peripheral inserts, clamp screw and wrench for no peripheral blade type body of φ20, φ25, φ30 and φ40.
 2. In case of using main blade -H type for semi-finishing, be sure to use same grade for sub blade.
 3. In case of using -N low cutting force inserts, be sure to use same notched inserts for main blade and sub blade together.

クランプねじ形番 Clamp screw	推奨トルク(N・m) Recommended torque
DSW-2563H	0.9
DSW-307H	1.8
DSW-4085	3.6
DSW-511H	6.1
TSW-511	5.5
TSW-614H	7.5
HSW-614H	7.5
ESW-206	0.9
CSW-407	3.6
ESW-406	3.1
CSW-510	5.5

SWB形 ロングシャンクタイプ・コンビネーションシャンクタイプ

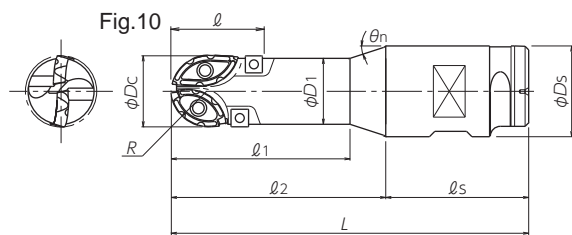
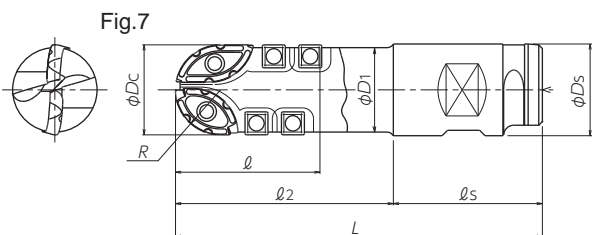
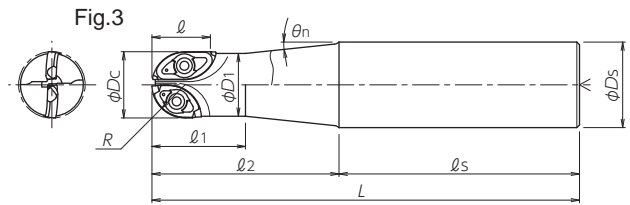
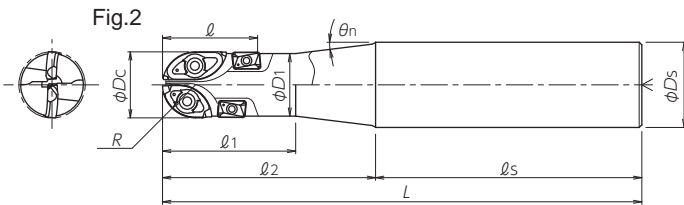

■本体 Body

シャンクタイプ Shank type	形番 Cat. No.	在庫 Stock	使用チップ数 No. of inserts			寸法(mm) Dimensions											Fig.
			主刃 Main blade	副刃 Sub blade	外周刃 Peripheral blade	R	φDc	ℓ	ℓ2	ℓs	L	ℓ1	φD1	θn	φDs	Md	
ロング Long	SWBX2018S32LS	●	1	1	—	10	20	18	70	280	350	30	18.7	8°30'	32	—	3
	SWBX2522S32LS	●	1	1	—	12.5	25	22	70	280	350	35	23.5	6°	32	—	3
	SWBE3040S32LS	●	1	1	2	15	30	40	100	250	350	60	28.2	2°	32	—	2
	SWBE3040S42LS	●	1	1	2			40	100	250	350	60	28.2	9°	42	—	2
	SWBE3025S32LS	●	1	1	—	20	40	25	100	250	350	50	28.2	1°30'	32	—	3
	SWBE3025S42LS	●	1	1	—			25	100	250	350	50	28.2	7°	42	—	3
SWBE4050S42LS	●	1	1	2	20	40	50	100	250	350	60	36.9	3°	42	—	2	
SWBE4035S42LS	●	1	1	—			35	100	250	350	60	36.9	3°	42	—	3	
コンビネーション Combination	SWBSS4050C508	●	1	1	2	20	40	50	80	80	160	60	36.9	18°	50.8	—	10
	SWBMS4050C508	●	1	1	2			50	140	80	220	120	36.9	18°	50.8	—	10
	SWBL4050C508	●	1	1	2	25	50	50	220	80	300	170	36.9	6°	50.8	—	10
	SWBE4050C508	●	1	1	2			50	270	80	350	170	36.9	3°	50.8	—	10
	SWBS5080C508	●	1	1	4	25	50	80	120	80	200	—	46.8	—	50.8	—	7
	SWBM5080C508	●	1	1	4			80	170	80	250	—	46.8	—	50.8	—	7
	SWBL5080C508	●	1	1	4	25	50	80	220	80	300	—	46.8	—	50.8	—	7
	SWBSS5060C508	●	1	1	2			60	80	80	160	—	46.8	—	50.8	—	10
	SWBMS5060C508	●	1	1	2	25	50	60	140	80	220	—	46.8	—	50.8	—	10
	SWBL5060C508	●	1	1	2			60	220	80	300	—	46.8	—	50.8	—	10
SWBE5060C508	●	1	1	2	25	50	60	270	80	350	—	46.8	—	50.8	—	10	

注) 1. 本体にチップは組込んでありません。 2. 溝加工時のフォーム誤差についてはP.25をご参照ください。
3. 用途により対応チップの組合せが異なります。チップの選定はP.8をご参照ください。

切削条件 Cutting conditions 22~27ページ

Note) 1. All cutters are supplied without inserts. 2. Please see page 25 for machined form error.
3. Please see page 8 for inserts combination.

Long shank type / Combination shank type

■部品 Parts

対応ホルダ Applicable holders ϕD_c	クランプねじ Clamp Screw		レンチ Wrench		チップ Inserts		
	主刃・副刃用 For main & sub	外周刃用 For peripheral	主刃・副刃用 For main & sub	外周刃用 For peripheral	主刃 Main blade	副刃 Sub blade	外周刃 Peripheral blade
$\phi 20$	DSW-307H	ESW-206	A-10	A-08SD	SWB220HM	SWB220HS	ZCMT100308R
					SWB220HM-H (中仕上げ用) (For semi-finishing)	SWB220HS (必ず主刃と同一材種を選択のこと) (Be sure to choose the same grade as main blade)	
					SWB220MMW (肉盛り加工用) (For welding & hardened)	SWB220MSW (肉盛り加工用) (For welding & hardened)	
$\phi 25$	DSW-4085	ESW-206	A-15	A-08SD	SWB225HM	SWB225HS	ZCMT100308R
					SWB225HM-H (中仕上げ用) (For semi-finishing)	SWB225HS (必ず主刃と同一材種を選択のこと) (Be sure to choose the same grade as main blade)	
					SWB225MMW (肉盛り加工用) (For welding & hardened)	SWB225MSW (肉盛り加工用) (For welding & hardened)	
$\phi 30$	DSW-511H	CSW-407	A-20	A-15	SWB230HM	SWB230HS	IM-SP32GS
					SWB230HM-H (中仕上げ用) (For semi-finishing)	SWB230HS (必ず主刃と同一材種を選択のこと) (Be sure to choose the same grade as main blade)	
					SWB230MMW (肉盛り加工用) (For welding & hardened)	SWB230MSW (肉盛り加工用) (For welding & hardened)	
$\phi 40$	TSW-614H	ESW-406	A-25	A-15	SWB240HMN	SWB240HSN	SPGA090304 SPMA090304
					SWB240MMW (肉盛り加工用) (For welding & hardened)	SWB240MSW (肉盛り加工用) (For welding & hardened)	
$\phi 50$	HSW-614H	CSW-510	A-30	A-20	SWB250HMN-N (低抵抗形) (For low cutting forces)	SWB250HSN-N (低抵抗形) (For low cutting forces)	IM-SP43GS
					SWB250MMW (肉盛り加工用) (For welding & hardened)	SWB250MSW (肉盛り加工用) (For welding & hardened)	

注) 1. $\phi 20$ 、 $\phi 25$ 、 $\phi 30$ 、 $\phi 40$ の外周刃なしタイプのホルダには、上記の外周刃および外周刃用ねじとレンチは不要です。
 2. 中仕上げ用-H形主刃を使用時の副刃は、必ず主刃と同一材種を使用ください。
 3. 低抵抗-N形は、必ず主刃と副刃セット(末尾-Nのセット)で使用ください。

Note) 1. No need to use peripheral inserts, clamp screw and wrench for no peripheral blade type body of $\phi 20$, $\phi 25$, $\phi 30$ and $\phi 40$.
 2. In case of using main blade -H type for semi-finishing, be sure to use same grade for sub blade.
 3. In case of using -N low cutting force inserts, be sure to use same notched inserts for main blade and sub blade together.

クランプねじ形番 Clamp screw	推奨トルク(N・m) Recommended torque
DSW-2563H	0.9
DSW-307H	1.8
DSW-4085	3.6
DSW-511H	6.1
TSW-511	5.5
TSW-614H	7.5
HSW-614H	7.5
ESW-206	0.9
CSW-407	3.6
ESW-406	3.1
CSW-510	5.5

SWB形 MTシャンクタイプ・ウェルドンシャンクタイプ・BTシャンクタイプ

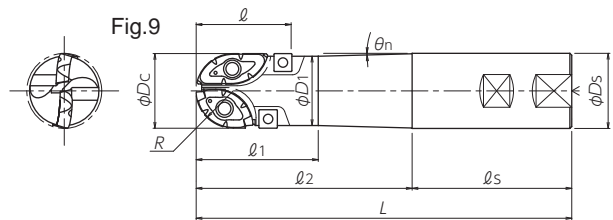
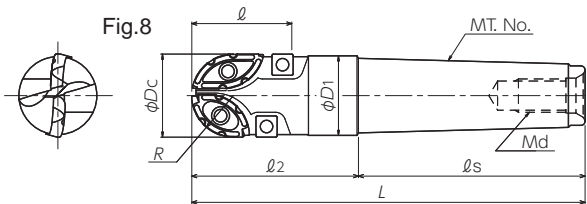

SWB-20070-MT3,
SWB-20100-MT3,
SWB-40090-MT5
の場合

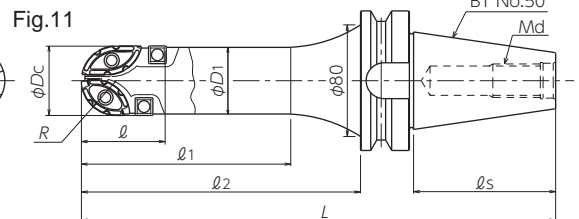
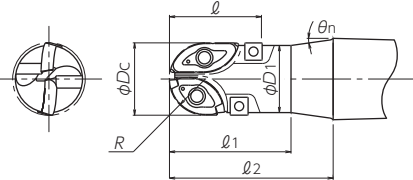

■本体 Body

シャンクタイプ Shank type	形番 Cat. No.	在庫 Stock	使用チップ数 No. of inserts			寸法(mm) Dimensions											Fig.
			主刃 Main blade	副刃 Sub blade	外周刃 Peripheral blade	R	φDc	ℓ	ℓ2	ℓs	L	ℓ1	φD1	θn	φDs	Md	
M T	SWB-20070-MT3	●	1	1	2	10	20	30	70	86	156	40	18.7	4°	MT3	M12×1.75	8
	SWB-20100-MT3	●	1	1	2			30	100	86	186	40	18.7	2°	MT3	M12×1.75	8
	SWB-25070-MT3	●	1	1	2	12.5	25	35	70	86	156	—	23.5	—	MT3	M12×1.75	8
	SWB-25100-MT3	●	1	1	2			35	100	86	186	—	23.5	—	MT3	M12×1.75	8
	SWB-30080-MT4	●	1	1	2	15	30	41	80	109	189	—	28.2	—	MT4	M16×2	8
	SWB-30120-MT4	●	1	1	2			41	120	109	229	—	28.2	—	MT4	M16×2	8
	SWB-32070-MT4-G	●	1	1	2	16	32	44	70	109	179	—	30.4	—	MT4	M16×2	8
	SWB-32100-MT4-G	●	1	1	2			44	100	109	209	—	30.4	—	MT4	M16×2	8
	SWB-40090-MT4	●	1	1	2	20	40	50	90	109	199	—	36.9	—	MT4	M16×2	8
	SWB-40090-MT5	●	1	1	2			50	90	136	226	66.8	36.9	8°	MT5	M20×2.5	8
SWB-50100-MT5	●	1	1	2	25	50	60	100	136	236	—	46.8	—	MT5	M20×2.5	8	
SWB-50120-MT5	●	1	1	2			60	120	136	256	—	46.8	—	MT5	M20×2.5	8	
SWB-50150-MT5	●	1	1	2			60	150	136	286	—	46.8	—	MT5	M20×2.5	8	
SWB-50170-MT5	●	1	1	2			60	170	136	306	—	46.8	—	MT5	M20×2.5	8	
SWB-32070-W32-G	●	1	1	2			16	32	44	70	80	150	—	30.4	—	W32	—
SWB-32090-W32-G	●	1	1	2	44	90			80	170	—	30.4	—	W32	—	9	
ウェルドン Weldon	SWB-32115-W40-G	●	1	1	2	16	32	44	115	85	200	50	29.9	4°10'	W40	—	9
	SWB-32165-W40-G	●	1	1	2			44	165	85	250	50	29.9	2°20'	W40	—	9
	SWB-40090-W40	●	1	1	2	20	40	50	90	85	175	—	36.9	—	W40	—	9
	SWB-40115-W40	●	1	1	2			50	115	85	200	65	36.9	1°30'	W40	—	9
	SWB-50100-W50	●	1	1	2	25	50	60	100	100	200	—	46.8	—	W50	—	9
	SWB-50150-W50	●	1	1	2			60	150	100	250	—	46.8	—	W50	—	9
B T	SWB-50200-BT50	●	1	1	2	25	50	60	200	101.8	339.8	150	46.8	—	BT50	M24×3	11
	SWB-50250-BT50	●	1	1	2			60	250	101.8	389.8	200	46.8	—	BT50	M24×3	11

注) 1. 本体にチップは組込んでおりません。2. 溝加工時のフォーム誤差についてはP.25をご参照ください。
3. 用途により対応チップの組合せが異なります。チップの選定はP.10をご参照ください。

切削条件 Cutting conditions 22~27ページ

Note) 1. All cutters are supplied without inserts. 2. Please see page 25 for machined form error.
3. Please see page 10 for inserts combination.

MT shank type / Weldon shank type / BT shank type

■部品 Parts

対応ホルダ Applicable holders ϕD_c	クランプねじ Clamp Screw		レンチ Wrench		チップ Inserts		
	主刃・副刃用 For main & sub	外周刃用 For peripheral	主刃・副刃用 For main & sub	外周刃用 For peripheral	主刃 Main blade	副刃 Sub blade	外周刃 Peripheral blade
$\phi 20$	DSW-307H	ESW-206	A-10	A-08SD	SWB220HM	SWB220HS	ZCMT100308R
					SWB220HM-H (中仕上げ用) (For semi-finishing)	SWB220HS (必ず主刃と同一材種を選択のこと) (Be sure to choose the same grade as main blade)	
					SWB220MMW (肉盛り加工用) (For welding & hardened)	SWB220MSW (肉盛り加工用) (For welding & hardened)	
$\phi 25$	DSW-4085	ESW-206	A-15	A-08SD	SWB225HM	SWB225HS	ZCMT100308R
					SWB225HM-H (中仕上げ用) (For semi-finishing)	SWB225HS (必ず主刃と同一材種を選択のこと) (Be sure to choose the same grade as main blade)	
					SWB225MMW (肉盛り加工用) (For welding & hardened)	SWB225MSW (肉盛り加工用) (For welding & hardened)	
$\phi 30$	DSW-511H	CSW-407	A-20	A-15	SWB230HM	SWB230HS	IM-SP32GS
					SWB230HM-H (中仕上げ用) (For semi-finishing)	SWB230HS (必ず主刃と同一材種を選択のこと) (Be sure to choose the same grade as main blade)	
					SWB230MMW (肉盛り加工用) (For welding & hardened)	SWB230MSW (肉盛り加工用) (For welding & hardened)	
$\phi 32$	TSW-511	ESW-206	A-20	A-08SD	SWB232HM-G	SWB232HS-G	ZCMT100308R
					SWB232MMW-G (肉盛り加工用) (For welding & hardened)	SWB232MSW-G (肉盛り加工用) (For welding & hardened)	
$\phi 40$	TSW-614H	ESW-406	A-25	A-15	SWB240HMN	SWB240HSN	SPGA090304 SPMA090304
					SWB240MMW (肉盛り加工用) (For welding & hardened)	SWB240MSW (肉盛り加工用) (For welding & hardened)	
$\phi 50$	HSW-614H	CSW-510	A-30	A-20	SWB250HMN-N (低抵抗形) (For low cutting forces)	SWB250HSN-N (低抵抗形) (For low cutting forces)	IM-SP43GS
					SWB250MMW (肉盛り加工用) (For welding & hardened)	SWB250MSW (肉盛り加工用) (For welding & hardened)	

注) 1. $\phi 20$ 、 $\phi 25$ 、 $\phi 30$ 、 $\phi 40$ の外周刃なしタイプのホルダには、上記の外周刃および外周刃用ねじとレンチは不要です。

2. 中仕上げ用-H形主刃を使用時の副刃は、必ず主刃と同一材種を使用ください。
3. 低抵抗-N形は、必ず主刃と副刃セット(末尾-Nのセット)で使用ください。

Note) 1. No need to use peripheral inserts, clamp screw and wrench for no peripheral blade type body of $\phi 20$, $\phi 25$, $\phi 30$ and $\phi 40$.

2. In case of using main blade -H type for semi-finishing, be sure to use same grade for sub blade.
3. In case of using -N low cutting force inserts, be sure to use same notched inserts for main blade and sub blade together.

クランプねじ形番 Clamp screw	推奨トルク(N・m) Recommended torque
DSW-2563H	0.9
DSW-307H	1.8
DSW-4085	3.6
DSW-511H	6.1
TSW-511	5.5
TSW-614H	7.5
HSW-614H	7.5
ESW-206	0.9
CSW-407	3.6
ESW-406	3.1
CSW-510	5.5

Swing Ball series

Indexable Ball Nose End Mill

SWB/SWE形 スウィングボールシリーズ

MSW
TYPE

スウィングボール モジュラーヘッド

Modular head MSW type

クーラント穴付き Through coolant hole

G-Body

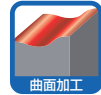
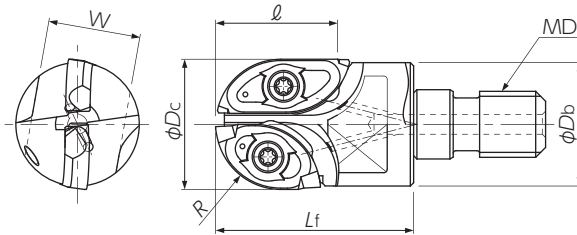

形番 Cat. No.	在庫 Stock	刃数 No. of inserts	寸法(mm) Dimensions							対応チップ Applicable inserts	部品 Parts	
			R	φDc	l	Lf	φDb	MD	W		クランプねじ Clamp screw	レンチ Wrench
NEW MSW-1615-M8	●	2	8	16	15	23	15	M8	12	主刃: SWB216HM 副刃: SWB216HS	DSW-2563H	A-08SD
MSW-2018-M10	●	2	10	20	18.5	30	18.7	M10	14	主刃: SWB220HM/HM-H/ MMW 副刃: SWB220HS/MSW	DSW-307H	A-10
MSW-2522-M12	●	2	12.5	25	21.9	35	23.5	M12	17	主刃: SWB225HM/HM-H/ MMW 副刃: SWB225HS/MSW	DSW-4085	A-15
MSW-3025-M16	●	2	15	30	25.9	43	28.2	M16	22	主刃: SWB230HM/HM-H/ MMW 副刃: SWB230HS/MSW	DSW-511H	A-20
MSW-3225-M16	●	2	16	32	29.5	43	29.9	M16	22	主刃: SWB232HM-G/MMW-G 副刃: SWB232HS-G/MSW-G	TSW-511	A-20

- 注) 1. ホルダにチップは組み込んでありません。別途お求めください。
 2. モジュラーヘッドの推奨締め付けトルクはP.12をご参照ください。
 3. 用途により対応チップの組合せが異なります。チップの選定はP.10をご参照ください。

- Note) 1. All cutters are supplied without inserts.
 2. Please see page 12 for recommended tightening torque.
 3. Please see page 10 for inserts combination.

アーバ Arbor 13~18ページ

切削条件 Cutting conditions 28~29ページ

クランプねじ形番 Clamp screw	推奨トルク(N・m) Recommended torque
DSW-2563H	0.9
DSW-307H	1.8
DSW-4085	3.6
DSW-511H	6.1
TSW-511	5.5

モジュラーヘッド使用上の注意事項 Attention

⚠️ モジュラーヘッド取り付け時の注意 Attention to mounting head and MSN/ MGN shank holder.

モジュラーヘッド締め付け手順 Tightening procedure

- ① **清掃 Cleaning**
モジュラーヘッド、オール超硬シャンクアーバ『頑固一徹』(もしくはスチールシャンクアーバ『頑固G-Body』)の締結部をエアにて清掃ください。
Remove dirt and chips with air from the connecting thread and shank holder.
- ② **仮締め Initial Tightening**
手締めにて、モジュラーヘッド端面とオール超硬シャンクアーバ『頑固一徹』(もしくはスチールシャンクアーバ『頑固G-Body』)端面が当たるまで仮締めしてください。
Tighten by hand until the head and the shank holder faces meet.
- ③ **本締め・チェック Final Tightening**
トルクコントロールスパナにて、規定トルク値でゆっくりと回転させ本締めしてください。隙間がないことを確認ください。
Tighten slowly with torque control spanner wrench and confirm that there is no gap.

(注) 仮締めせずに端面に隙間がある状態で本締めすると、ねじ部より破断する危険性があります。
Attention : Final tightening without initial tightening cause connecting thread break.

⚠️ 注意事項

1. スパナはトルクコントロールスパナ、もしくは専用スパナ(DSタイプ)を必ず使用ください(以下トルク値を参照ください)。
2. スパナは、締め付け方向にゆっくりと回転させて本締めください。
3. モジュラーヘッドとオール超硬シャンクアーバ『頑固一徹』(もしくはスチールシャンクアーバ『頑固G-Body』)の端面を密着させて、隙間がないことを確認ください。

Note) 1. Only use the torque control spanner wrench or DIJET DS type spanner wrench.
2. Please turn the spanner wrench slowly during use.
3. Please confirm that there is no gap.

ねじサイズ Thread	締め付けトルク Tightening Torque	二面幅 W(mm) Spanner size
M8	16N・m	10, 12 [☆]
M10	16N・m	14, 15
M12	20N・m	17
M16	25N・m	22, 26

注) 1. スパナはモジュラーヘッド本体には付属しておりません。別途お求めください。
2. 二面幅W=12(☆印参照)のモジュラーヘッドにつきましては、専用スパナDS-12をご用意しております。

Note) 1. Modular heads are supplied without spanner wrench.
2. ☆ mark shows: DIJET have a stock of DS-12 type spanner wrenches.

⚠️ 頑固一徹(モジュラーヘッド用オール超硬シャンクアーバ) 選定時の注意 Selection of "MSN Carbide shank holder"

外径φ16超のモジュラーヘッドを使用する場合は、外径より1mm以上首径の細い頑固一徹を選定してください。
切りくずのかみ込みにより、頑固一徹が折損する危険があります。

In case of using modular head over φ16mm,
please select MSN carbide shank that diameter (φD1) is 1mm or more smaller than modular head (φDc).
A wrong selection causes the carbide shank damage.

φDc - φD1 ≥ 1mm で選定

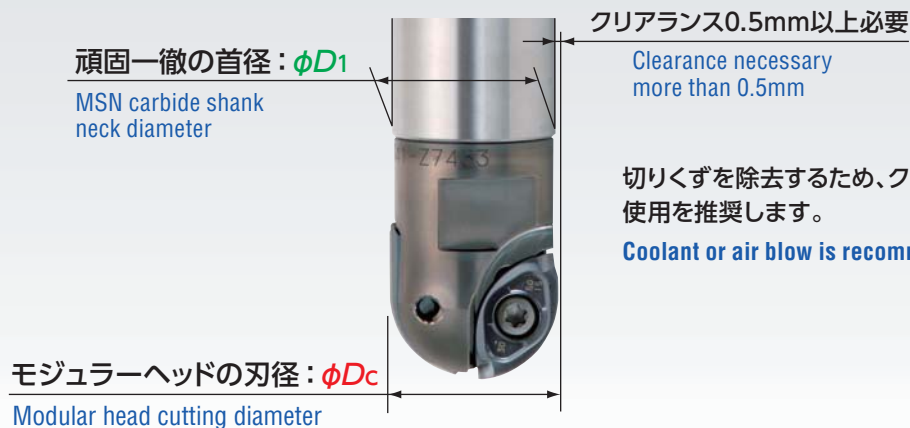

切りくずを除去するため、クーラント、エアブローの使用を推奨します。
Coolant or air blow is recommended to remove the chips.

⚠️ 焼きばめホルダへの取り付け時の注意 Caution for the mounting to shrink fit holder.

オール超硬シャンクアーバ『頑固一徹』とモジュラーヘッドを焼きばめホルダで使用する際は、モジュラーヘッドをはずして、『頑固一徹』のみを焼きばめして取り付けてください。ヘッドの取り付けは、焼きばめ後に行ってください。

When you use a carbide shank and a modular head on the shrink fit holder, please shrink fit the only carbide shank without mounting a modular head together. Please mount a modular head after shrinking fit.

注) ヘッドを付けたまま焼きばめを行うと、ヘッドやチップがはずれにくくなる場合があります。

Note) If it shrink fit with mounting a modular head, the head and insert will become difficult to loose.

MSN
TYPE

頑固一徹 (モジュラーヘッド用オール超硬シャンクアーバ)

MSN Carbide shank holder

クーラント穴付き Through coolant hole

高能率加工用 For high productivity

頑固一徹

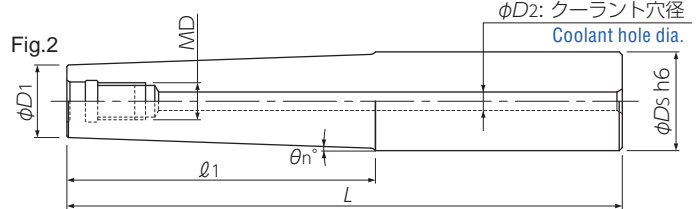
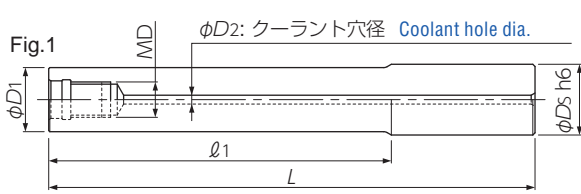

エンドミルシャンクタイプ End mill shank type

形番 Cat. No.	在庫 Stock	寸法(mm) Dimensions							重量(kg) Weight	Fig.
		φDs	ℓ1	L	φD1	θn°	MD	φD2		
MSN-M8-20-S16C	●	16	20	75	15.5	—			0.17	1
MSN-M8-40-S16C	●	16	40	95	15.5	—			0.22	1
NEW MSN-M8-40T-S20C	●	20	40	100	14.5	3° 30'			0.36	2
NEW MSN-M8-77T-S20C	●	20	77	143	14.5	1° 45'	M8	4	0.49	2
MSN-M8-80-S16C	●	16	80	135	15.5	—			0.32	1
MSN-M8-120-S16C	●	16	120	175	15.5	—			0.42	1
NEW MSN-M8-152-S16C	●	16	152	207	15.5	—			0.51	1
MSN-M10-20-S20C	●	20	20	80	19.5	—		6	0.29	1
MSN-M10-40-S20C	●	20	40	100	19.5	—			0.39	1
MSN-M10-40T-S20C	●	20	40	100	18.5	0° 43'			0.39	2
MSN-M10-70-S20C	●	20	70	130	19.5	—			0.50	1
NEW MSN-M10-85T-S25C	●	25	85	161	18.5	2°			0.90	2
MSN-M10-90-S20C	●	20	90	150	19.5	—	M10	4	0.60	1
MSN-M10-90T-S20C	●	20	90	150	18.5	0° 19'			0.58	2
MSN-M10-140-S20C	●	20	140	200	19.5	—			0.80	1
MSN-M10-140T-S20C	●	20	140	200	18.5	0° 12'			0.77	2
NEW MSN-M10-160-S20C	●	20	160	220	19.5	—			0.87	1
NEW MSN-M10-210-S20C	●	20	210	270	19.5	—			1.07	1

注) モジュラーヘッドの推奨締め付けトルクはP.12をご参照ください。 (Note) Please see page 12 for recommended tightening torque.

MSN
TYPE

頑固一徹 (モジュラーヘッド用オール超硬シャンクアーバ)

MSN Carbide shank holder

クーラント穴付き Through coolant hole

高能率加工用 For high productivity

頑固一徹

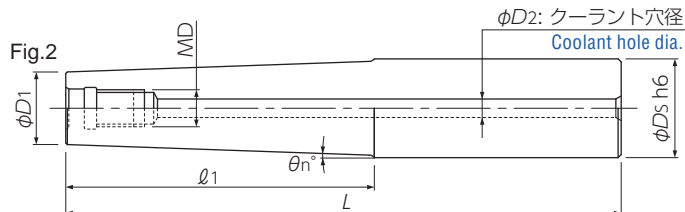
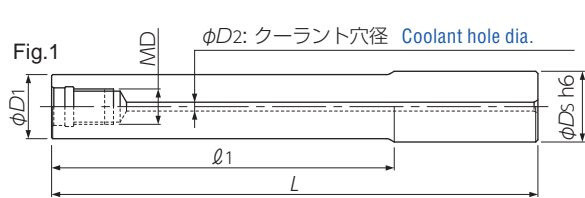

エンドミルシャンクタイプ End mill shank type

形番 Cat. No.	在庫 Stock	寸法(mm) Dimensions							重量(kg) Weight	Fig.
		φDs	ℓ1	L	φD1	θn°	MD	φD2		
MSN-M12-25-S25C	●	25	25	90	24	—			0.53	1
MSN-M12-55-S25C	●	25	55	120	24	—			0.72	1
NEW MSN-M12-100T-S32C	●	32	100	180	23.5	2°			1.61	2
MSN-M12-105-S25C	●	25	105	170	24	—	M12	6	1.03	1
NEW MSN-M12-135-S25C	●	25	135	215	24	—			1.30	1
MSN-M12-155-S25C	●	25	155	220	24	—			1.34	1
NEW MSN-M12-200-S25C	●	25	200	265	24	—			1.58	1
MSN-M16-25-S32C	●	32	25	90	29	—			0.85	1
MSN-M16-55-S32C	●	32	55	120	29	—			1.13	1
NEW MSN-M16-77-S32C	●	32	77	157	29	—			1.47	1
NEW MSN-M16-97-S32C	●	32	97	177	29	—			1.64	1
MSN-M16-105-S32C	●	32	105	170	29	—			1.59	1
NEW MSN-M16-117T-S32C	●	32	117	197	29	0° 38'			1.88	2
NEW MSN-M16-127-S32C	●	32	127	207	29	—			1.89	1
NEW MSN-M16-127T-S32C	●	32	127	207	29	0° 30'	M16	8	2.23	2
MSN-M16-155-S32C	●	32	155	220	29	—			2.04	1
NEW MSN-M16-177-S32C	●	32	177	257	29	—			2.32	1
NEW MSN-M16-177T-S32C	●	32	177	257	29	0° 23'			2.78	2
MSN-M16-195-S32C	●	32	195	260	29	—			2.40	1
NEW MSN-M16-197T-S32C	●	32	197	277	29	0° 23'			3.00	2
MSN-M16-225-S32C	●	32	225	290	29	—			2.57	1
MSN-M16-245-S32C	●	32	245	310	29	—			2.74	1
MSN-M16-295-S32C	●	32	295	360	29	—			3.17	1

注) モジュラーヘッドの推奨締付けトルクはP.12をご参照ください。 (Note) Please see page 12 for recommended tightening torque.

● : メーカー在庫品 Standard stock items

◎ : 近日在庫品 Soon to be stocked

○ : 在庫がなくなり次第廃番 Soon to be deleted



頑固一徹 (モジュラーヘッド用オール超硬シャンクアーバ)

MSN Carbide shank holder

クーラント穴付き Through coolant hole

高能率加工用 For high productivity

頑固一徹

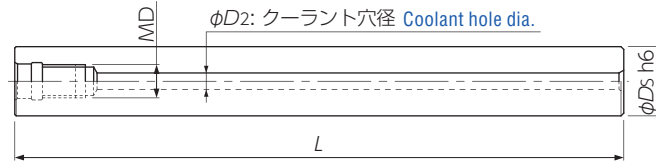

ストレートアーバタイプ Straight arbor type

形番 Cat. No.	在庫 Stock	寸法(mm) Dimensions				重量(kg) Weight
		φDs	L	MD	φD2	
MSN-M8-97S-S15C	●		97			0.21
MSN-M8-147S-S15C	●	15	147	M8	4	0.33
NEW MSN-M8-197S-S15C	●		197			0.44
MSN-M8-107S-S16C	●	16	107	M8	4	0.27
MSN-M8-157S-S16C	●		157			0.40
MSN-M10-130S-S18C	●		130			0.42
MSN-M10-190S-S18C	●	18	190	M10	4	0.62
NEW MSN-M10-240S-S18C	●		240			0.89
MSN-M10-130S-S20C	●		130			0.53
MSN-M10-190S-S20C	●	20	190	M10	4	0.78
MSN-M10-250S-S20C	●		250			1.02
MSN-M12-185S-S23C	●	23	185	M12	6	0.98
MSN-M12-265S-S23C	●		265			1.42
NEW MSN-M12-185S-S24C	●	24	185	M12	6	1.07
NEW MSN-M12-265S-S24C	●		265			1.54
MSN-M12-145S-S25C	●		145			0.91
MSN-M12-215S-S25C	●	25	215	M12	6	1.36
MSN-M12-285S-S25C	●		285			1.80
MSN-M16-160S-S28C	●		160			1.22
MSN-M16-230S-S28C	●	28	230	M16	8	1.77
MSN-M16-310S-S28C	●		310			2.41
MSN-M16-157S-S32C	●		157			1.61
MSN-M16-217S-S32C	●	32	217	M16	8	2.22
MSN-M16-287S-S32C	●		287			2.94
MSN-M16-357S-S32C	●		357			3.66

注) モジュラーヘッドの推奨締め付けトルクはP.12をご参照ください。

Note) Please see page 12 for recommended tightening torque.

MGN
TYPE

頑固 G-Body (モジュラーヘッド用スチールシャンクアーバ)

MGN G-Body steel shank holder

クーラント穴付き Through coolant hole

頑固 G-Body

- 高剛性かつ耐久性に優れるG-Body ●ショートタイプ
- 突出し長さが短い加工や荒加工時の切りくず噛みこみによる破損対策には、コストパフォーマンスにも優れた頑固G-Body(スチールシャンク)を推奨いたします。

NEW

- Adopted ultra-rigid and improved body durability "G-Body".
- Short type
- Cost-effective and high strength steel shank holder.

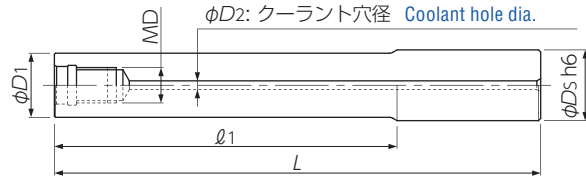

エンドミルシャンクタイプ End mill shank type

形番 Cat. No.	在庫 Stock	寸法(mm) Dimensions							重量(kg) Weight
		φDs	ℓ1	L	φD1	θn°	MD	φD2	
MGN-M8-17-S16	●	16	17	97	15.5	—	M8	4	0.13
MGN-M10-30-S20	●	20	30	100	19	—	M10	4	0.21
MGN-M12-35-S25	●	25	35	105	24	—	M12	4	0.36
MGN-M12-85-S25	●	25	85	165	24	—	M12	4	0.57
MGN-M16-37-S32	●	32	37	107	29	—	M16	6	0.56
MGN-M16-77-S32	●	32	77	157	29	—	M16	6	0.83

注) 1. モジュラーヘッドと頑固G-Body組み合わせ時の切削条件は、P.28～29の標準切削条件表をそのまま適用ください。
2. モジュラーヘッドの推奨締付けトルクはP.12をご参照ください。

Note) 1. In case of using modular head combined with MGN steel shank holder, apply the recommended cutting conditions sheet (see page 28-29).
2. Please see page 12 for recommended tightening torque.

G-Body

耐熱性に優れた強靱性鋼+表面のGN処理により、表面硬さ65HRC以上と高硬度かつ熱変形に強く高剛性で、本体耐久性および工具寿命を従来他社品比30%以上アップ。過酷な加工条件にも威力を発揮します。さらに、切りくずの溶着、錆の発生を抑制する効果もあります。

Adopted GN surface-hardening treatment on thermal resistant high strength steel gives high hardness over 65HRC and secure insert pocket and holder against thermal deformation, improved body durability and tool life by 30% or more, compared with competitor's tool. Make it difficult to be damaged even under severe cutting conditions. Also rust-proof and anti-welding effect is much improved.

MSA
TYPE

頑固一体 (超硬シャンク一体型)

MSA Arbor integrated carbide shank

クーラント穴付き Through coolant hole

高効率加工用 For high productivity

頑固一体

NEW

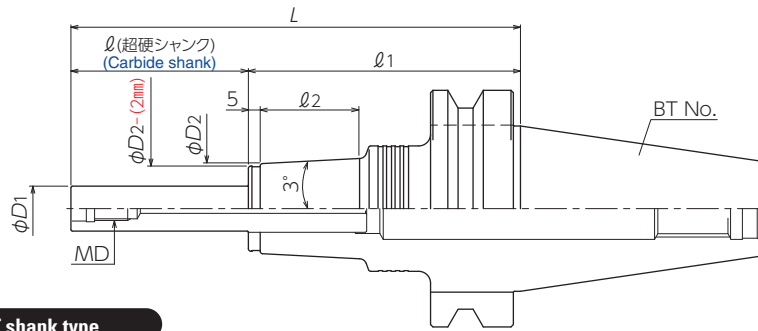

BT シャンクタイプ BT shank type

形番 Cat. No.	在庫 Stock	寸法(mm) Dimensions								重量(kg) Weight
		φ (超硬部)	l ₁	l ₂	L	φD ₁	MD	φD ₂	BT No.	
MSA-M8-105-25-BT40	※	25	80	22	105	15	M8	32	BT40	1.4
MSA-M8-130-50-BT40	※	50	80	22	130	15	M8	32	BT40	1.4
MSA-M8-155-75-BT40	※	75	80	22	155	15	M8	32	BT40	1.5
MSA-M8-165-85-BT40	※	85	80	22	165	15	M8	32	BT40	1.5
MSA-M10-125-25-BT40	※	25	100	42	125	19	M10	38	BT40	1.8
MSA-M10-150-50-BT40	※	50	100	42	150	19	M10	38	BT40	1.9
MSA-M10-175-75-BT40	※	75	100	42	175	19	M10	38	BT40	2.0
MSA-M10-200-100-BT40	※	100	100	42	200	19	M10	38	BT40	2.0
MSA-M12-125-25-BT40	※	25	100	42	125	24	M12	45	BT40	2.0
MSA-M12-150-50-BT40	※	50	100	42	150	24	M12	45	BT40	2.1
MSA-M12-175-75-BT40	※	75	100	42	175	24	M12	45	BT40	2.3
MSA-M12-200-100-BT40	※	100	100	42	200	24	M12	45	BT40	2.4
MSA-M8-120-25-BT50	※	25	95	22	120	15	M8	32	BT50	4.0
MSA-M8-145-50-BT50	※	50	95	22	145	15	M8	32	BT50	4.0
MSA-M8-170-75-BT50	※	75	95	22	170	15	M8	32	BT50	4.1
MSA-M8-180-85-BT50	※	85	95	22	180	15	M8	32	BT50	4.1
MSA-M10-140-25-BT50	※	25	115	42	140	19	M10	38	BT50	4.3
MSA-M10-165-50-BT50	※	50	115	42	165	19	M10	38	BT50	4.4
MSA-M10-190-75-BT50	※	75	115	42	190	19	M10	38	BT50	4.5
MSA-M10-215-100-BT50	※	100	115	42	215	19	M10	38	BT50	4.5
MSA-M12-140-25-BT50	※	25	115	42	140	24	M12	45	BT50	4.6
MSA-M12-165-50-BT50	※	50	115	42	165	24	M12	45	BT50	4.7
MSA-M12-190-75-BT50	※	75	115	42	190	24	M12	45	BT50	4.9
MSA-M12-215-100-BT50	※	100	115	42	215	24	M12	45	BT50	5.0
MSA-M12-240-125-BT50	※	125	115	42	240	24	M12	45	BT50	5.2
MSA-M16-140-25-BT50	※	25	115	42	140	29	M16	54	BT50	5.4
MSA-M16-165-50-BT50	※	50	115	42	165	29	M16	54	BT50	5.6
MSA-M16-190-75-BT50	※	75	115	42	190	29	M16	54	BT50	5.8
MSA-M16-215-100-BT50	※	100	115	42	215	29	M16	54	BT50	6.0
MSA-M16-240-125-BT50	※	125	115	42	240	29	M16	54	BT50	6.2

注) 1. モジュラーヘッドと頑固一体組み合わせ時の切削条件は、P.28~29の標準切削条件表をそのまま適用ください。
2. モジュラーヘッドの推奨締付けトルクはP.12をご参照ください。
3. プルスタッドは付属していません。

Note) 1. In case of using modular head combined with MSA arbor, apply the recommended cutting conditions sheet (see page 28-29).
2. Please see page 12 for recommended tightening torque.
3. MSA arbor is supplied without pull studs.

MSA
TYPE

頑固一体 (超硬シャンク一体型) MSA Arbor integrated carbide shank

クーラント穴付き Through coolant hole 高能率加工用 For high productivity

頑固一体

NEW

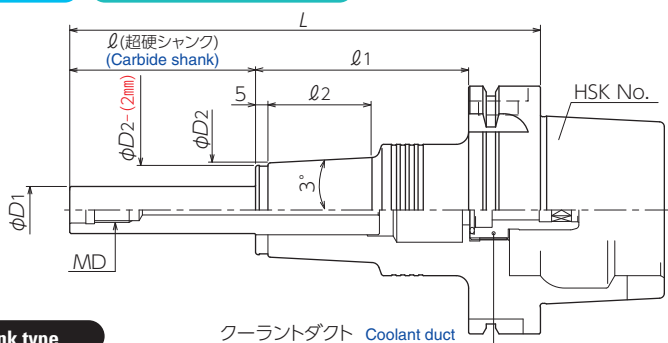

HSK シャンクタイプ HSK shank type

形番 Cat. No.	在庫 Stock	寸法(mm) Dimensions								重量(kg) Weight
		l (超硬部)	l ₁	l ₂	L	φD ₁	MD	φD ₂	HSK No.	
MSA-M8-105-25-A63	※	25	80	22	105	15	M8	32	A63	1.3
MSA-M8-130-50-A63	※	50	80	22	130	15	M8	32	A63	1.3
MSA-M8-155-75-A63	※	75	80	22	155	15	M8	32	A63	1.4
MSA-M8-165-85-A63	※	85	80	22	165	15	M8	32	A63	1.4
MSA-M10-125-25-A63	※	25	100	42	125	19	M10	38	A63	1.6
MSA-M10-150-50-A63	※	50	100	42	150	19	M10	38	A63	1.7
MSA-M10-175-75-A63	※	75	100	42	175	19	M10	38	A63	1.8
MSA-M10-200-100-A63	※	100	100	42	200	19	M10	38	A63	1.8
MSA-M12-125-25-A63	※	25	100	42	125	24	M12	45	A63	1.9
MSA-M12-150-50-A63	※	50	100	42	150	24	M12	45	A63	2.0
MSA-M12-175-75-A63	※	75	100	42	175	24	M12	45	A63	2.2
MSA-M12-200-100-A63	※	100	100	42	200	24	M12	45	A63	2.3
MSA-M8-120-25-A100	※	25	95	22	120	15	M8	32	A100	2.6
MSA-M8-145-50-A100	※	50	95	22	145	15	M8	32	A100	2.6
MSA-M8-170-75-A100	※	75	95	22	170	15	M8	32	A100	2.7
MSA-M8-180-85-A100	※	85	95	22	180	15	M8	32	A100	2.7
MSA-M10-140-25-A100	※	25	115	42	140	19	M10	38	A100	3.1
MSA-M10-165-50-A100	※	50	115	42	165	19	M10	38	A100	3.2
MSA-M10-190-75-A100	※	75	115	42	190	19	M10	38	A100	3.3
MSA-M10-215-100-A100	※	100	115	42	215	19	M10	38	A100	3.3
MSA-M12-140-25-A100	※	25	115	42	140	24	M12	45	A100	3.4
MSA-M12-165-50-A100	※	50	115	42	165	24	M12	45	A100	3.5
MSA-M12-190-75-A100	※	75	115	42	190	24	M12	45	A100	3.7
MSA-M12-215-100-A100	※	100	115	42	215	24	M12	45	A100	3.8
MSA-M12-240-125-A100	※	125	115	42	240	24	M12	45	A100	4.0
MSA-M16-140-25-A100	※	25	115	42	140	29	M16	54	A100	4.1
MSA-M16-165-50-A100	※	50	115	42	165	29	M16	54	A100	4.3
MSA-M16-190-75-A100	※	75	115	42	190	29	M16	54	A100	4.5
MSA-M16-215-100-A100	※	100	115	42	215	29	M16	54	A100	4.7
MSA-M16-240-125-A100	※	125	115	42	240	29	M16	54	A100	4.9

注) 1. モジュラーヘッドと頑固一体組み合わせ時の切削条件は、P.28~29の標準切削条件表をそのまま適用ください。
2. モジュラーヘッドの推奨締付けトルクはP.12をご参照ください。

Note) 1. In case of using modular head combined with MSA arbor, apply the recommended cutting conditions sheet (see page 28-29).
2. Please see page 12 for recommended tightening torque.

スウィングボール対応チップ Inserts for "SWING BALL"

■SWB-N形 (低抵抗形)

1. 大荒加工φ50用に低抵抗-N形を追加。
2. 従来品に比べ切削抵抗を15%低減。
びびり振動や切削音も低減。



SWB-N type (For low cutting forces)

1. Available now new insert for low cutting forces. Suitable for heavy roughing.
2. 15% reduced cutting forces compared with regular type.
More smooth and calm cutting are achieved.

Fig.1 (主刃・低抵抗形)
(Main blade / For low cutting forces)

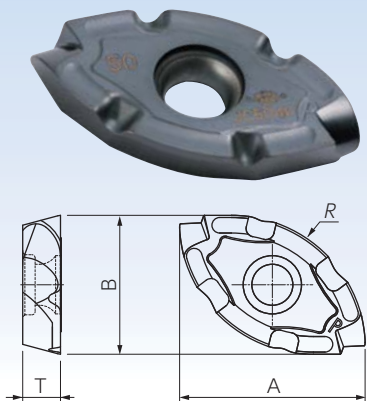
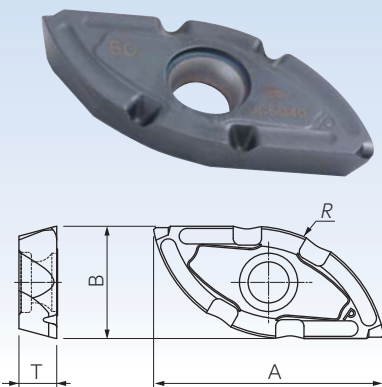

Fig.2 (副刃・低抵抗形)
(Sub blade / For low cutting forces)



■SWB-H形 (中仕上げ用)

1. φ20, 25, 30用に中仕上げ用-H形を追加。
2. 従来品に比べ渦巻き刃部のR精度を良くしたことにより、中仕上げへの使用が可能。
(荒加工用としての使用は推奨しません。)

SWB-H type (Main blade for semi-finishing)

1. Added -H type semi-finishing main blade for φ20, φ25 and φ30.
2. Able to use for semi-finishing by improving nose radius accuracy.
Do not recommend to use for roughing.

Fig.3 (主刃・中仕上げ用)
(Main blade for semi-finishing)

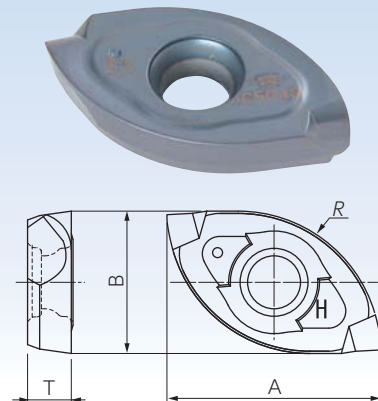

Fig.4 (主刃)
(Main blade)

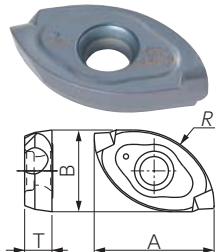

Fig.5 (主刃)
(Main blade)

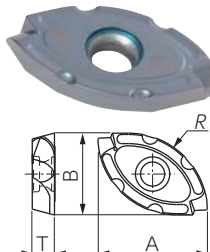

Fig.6 (副刃)
(Sub blade)

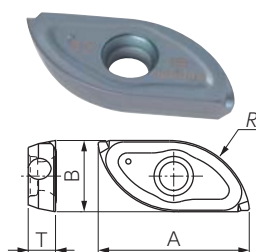

Fig.7 (副刃)
(Sub blade)

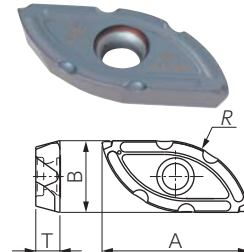

Fig.8 (主刃・肉盛り加工用)

※高硬度材にも対応
(Main blade for welding & hardened)

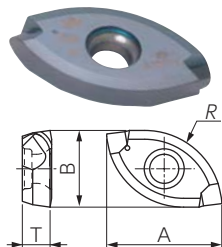

Fig.9 (副刃・肉盛り加工用)

※高硬度材にも対応
(Sub blade for welding & hardened)

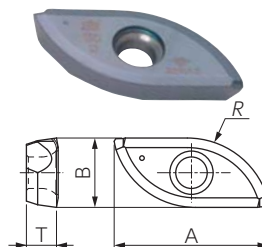

Fig.10 (外周刃)
(Peripheral blade)

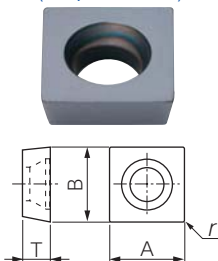

Fig.11 (外周刃)
(Peripheral blade)

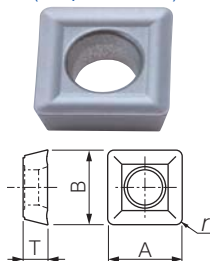
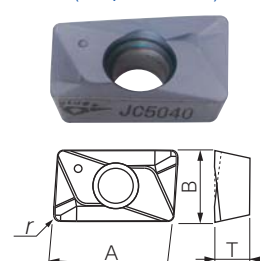

Fig.12 (外周刃)
(Peripheral blade)



形番 Cat. No.	タイプ Type	PVD コーティング PVD coated					寸法(mm) Dimensions					Fig.
		JC5015	JC5118	JC8015	JC8050	JC5040	R	A	B	T	r	
NEW SWB216HM	主刃 Main blade		●		●		8	15	7.9	3	—	4
NEW SWB216HS	副刃 Sub blade		●		●			16.1	6.6	3	—	6
SWB220HM				●		●		15.8	9.9	3.65	—	4
SWB220HM-H	主刃 Main blade			●				16	9.9	3.65	—	3
SWB220MMW				●			10	15.8	9.9	3.65	—	8
SWB220HS	副刃 Sub blade			●		●		20	8.2	3.65	—	6
SWB220MSW				●				20	8.2	3.65	—	9
SWB225HM				●		●		18.5	12.4	3.8	—	4
SWB225HM-H	主刃 Main blade			●				18.9	12.4	3.8	—	3
SWB225MMW				●			12.5	18.5	12.4	3.8	—	8
SWB225HS	副刃 Sub blade			●		●		23.8	10.5	3.8	—	6
SWB225MSW				●				23.8	10.5	3.8	—	9
SWB230HM				●		●		22.2	14.8	5.35	—	4
SWB230HM-H	主刃 Main blade			●				22.4	14.8	5.35	—	3
SWB230MMW				●			15	22.2	14.8	5.35	—	8
SWB230HS	副刃 Sub blade			●		●		27.5	12.3	5.35	—	6
SWB230MSW				●				27.5	12.3	5.35	—	9
SWB232HM-G	主刃 Main blade			●		●		26	16	5.35	—	4
SWB232MMW-G				●			16	26	16	5.35	—	8
SWB232HS-G	副刃 Sub blade			●		●		31.7	13.9	5.35	—	6
SWB232MSW-G				●				31.7	13.9	5.35	—	9
SWB240HMN	主刃 Main blade			●		●		30.4	20.8	6.85	—	5
SWB240MMW				●			20	30.4	20.8	6.85	—	8
SWB240HSN	副刃 Sub blade			●		●		37.5	16.3	6.85	—	7
SWB240MSW				●				37.5	16.3	6.85	—	9
SWB250HMN-N	主刃 Main blade			●		●		34.4	25.7	7	—	1
SWB250MMW				●			25	34.4	25.7	7	—	8
SWB250HSN-N	副刃 Sub blade			●		●		42.6	20.8	7	—	2
SWB250MSW				●				42.6	20.8	7	—	9
SPGA090304						●		9.525	9.525	3.18	0.4	10
SPMA090304		●		●				9.525	9.525	3.18	0.4	10
IM-SP43GS	外周刃 Peripheral blade					●	—	12.70	12.70	4.76	0.8	11
IM-SP32GS		●				●		9.525	9.525	3.18	0.8	11
ZCMT100308R		●				●		10.4	6.35	3.4	0.8	12

1ケース10個入りです。ただしR20以上主刃およびR16以上副刃は、1ケース5個入りです。
 10 inserts per case, but main blade (R20, R25) and sub blade (R16, R20, R25) are packed in 5 pcs. per case.

注) 1. 標準切削条件はP.22~29を、溝加工時のフォーム誤差についてはP.25をご参照ください。
 2. 中仕上げ用-H形主刃を使用時の副刃は、必ず主刃と同一材種を使用ください。
 3. 低抵抗-N形は、必ず主刃と副刃セット(末尾-Nのセット)で使用ください。

Note) 1. Please see page 22-29 for cutting conditions, and page 25 for machined form error.
 2. In case of using main blade -H type for semi-finishing, be sure to use same grade for sub blade.
 3. In case of using -N low cutting force inserts, be sure to use same notched inserts for main blade and sub blade together.

スウィングボールの加工事例 Cutting data for "SWING BALL"

1. 高送り加工例 High feed machining

	被加工材料 Work	名称	Part name	プレス金型 Stamping die	
		被削材	Material	SX105V工具鋼 (Tool Steel) 荒加工 Roughing	
		硬さ	Hardness	-	
使用工具 Tool	形番	Tool No.	SWB-50100-MT5		
	チップ形番、材種	Insert No.	SWB250HMN-N(JC5040), SWB250HSN-N(JC5040)		
	加工条件 Cutting conditions	切削速度、回転速度 $V_c, (n)$	314 m/min, (2,000 min ⁻¹)		
結果 Result	加工条件 Cutting conditions	送り速度 V_f	1,200 mm/min		
		a_p	10 mm		
		a_e	8 mm		
		クーラント	Coolant	乾式 Dry cut	
		使用機械	Machine	門形MC MC	
切削抵抗低く、良好。欠けもなく、1チップ(2コーナ)で加工できた。 Low cutting force, no chipping, completion of production of this component by one insert.					

2. JC8015での寿命改善事例(寿命2倍以上) Improved tool life by JC8015 (Two times longer life)

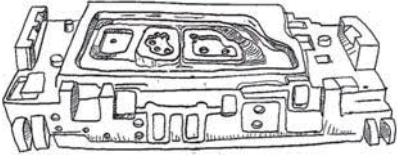
	被加工材料 Work	名称	Part name	プレス金型 Stamping die	
		被削材	Material	GM241 Alloy cast iron	
		硬さ	Hardness	260-320HB	
使用工具 Tool	形番	Tool No.	SWBS5060C508		
	チップ形番、材種	Insert No.	SWB250HMN-N(JC8015), SWB250HSN-N(JC8015)		
	加工条件 Cutting conditions	切削速度、回転速度 $V_c, (n)$	191 m/min, (1,215 min ⁻¹)		
結果 Result	加工条件 Cutting conditions	送り速度 V_f	560 mm/min		
		a_p	20 mm		
		a_e	12 mm		
		クーラント	Coolant	乾式 Dry cut	
		使用機械	Machine	門形MC MC	
GM241の大荒加工。従来品は2時間で $VB_{max}=0.7\text{mm}$ にて寿命に対しJC8015チップは $VB_{max}=0.2\text{mm}$ で2倍以上の寿命を得た。 Heavy roughing for GM241. Current insert got $VB_{max}=0.7\text{mm}$ after 2 hours. JC8015 insert got $VB_{max}=0.2\text{mm}$ and 2 times longer tool life.					

3. 肉盛り部加工例 Machining welding part

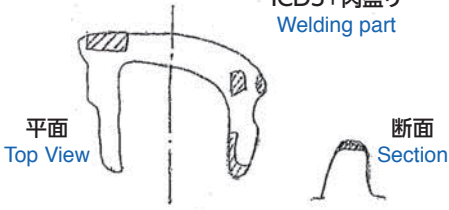
	被加工材料 Work	名称	Part name	プレス金型 Stamping die	
		被削材	Material	ICD5+肉盛り Cast steel+welding	
		硬さ	Hardness	58HRC	
使用工具 Tool	形番	Tool No.	SWBS5060C508		
	チップ形番、材種	Insert No.	SWB250MMW(JC8015), SWB250MSW(JC8015)		
	加工条件 Cutting conditions	切削速度、回転速度 $V_c, (n)$	191 m/min, (1,215 min ⁻¹)		
結果 Result	加工条件 Cutting conditions	送り速度 V_f	420 mm/min		
		a_p	1~3 mm		
		a_e	6 mm		
		クーラント	Coolant	乾式 Dry cut	
		使用機械	Machine	門形MC MC	
肉盛り部、40分加工して欠損もなく、良好。 After 40 minutes, inserts were still good conditions. No breakage.					

4. ボタンダイ(SKD11, 58~60HRC)加工例 Machining pierce die (Faster feed and longer tool life)

	被加工材料 Work	名称	Part name	プレス金型 Stamping die	
		被削材	Material	SKD11 Die steel (1.2379)	
		硬さ	Hardness	58-60HRC	
使用工具 Tool	形番	Tool No.	SWBM3040S32		
	チップ形番、材種	Insert No.	SWB230MMW(JC8015), SWB230MSW(JC8015)		
	加工条件 Cutting conditions	切削速度、回転速度 $V_c, (n)$	94 m/min, (1,000 min ⁻¹)		
結果 Result	加工条件 Cutting conditions	送り速度 V_f	300 mm/min		
		a_p	3 max (mm)		
		a_e	3~5 mm		
		クーラント	Coolant	乾式 Dry cut	
		使用機械	Machine	門形MC MC	
他社製は1型加工にてチップングがひどくチップ交換。スウィングボールは送り速度1.5倍で、3型以上加工可能。寿命も3倍以上。 After machined 1 die, current tool got damage and indexed. Swing Ball could increase feed speed 50% and machined 3 dies or more.					

φ50mm スウィングボール標準切削条件表 Recommended cutting conditions for Swing Ball 50mm dia.

加工形態 Type of machining						
被削材 Materials	チップ材種 Grade	切削条件 Parameter	溝加工 Slotting	肩削り加工 Shoulder cutting		深い肩削り加工 Shoulder cutting
中炭素鋼 (S50C, S55C) 硬さ150-250HB Medium carbon steel (C50, C55) 150-250HB	JC5040	n (min ⁻¹)	1,500	1,500	1,500	1,200
		V_f (mm/min)	720	1,000	680	420
		a_p (mm)	15	10	25	40
		a_e (mm)	—	10	15	10
鋳鋼 (GM190, ICD5) 硬さ150-285HB Cast steel (1.7225) 150-285HB	JC5040	n (min ⁻¹)	1,350	1,350	1,350	1,100
	JC8015 (40HRC以上) JC8015 (above 40HRC)	V_f (mm/min)	650	900	600	380
	a_p (mm)	15	10	25	40	
	a_e (mm)	—	10	15	10	
工具鋼 (SKD11, SX105V) 硬さ150-255HB Die steel (1.2379) 150-255HB	JC5040	n (min ⁻¹)	1,250	1,250	1,250	1,000
		V_f (mm/min)	550	750	500	300
		a_p (mm)	15	10	25	40
		a_e (mm)	—	10	15	5
焼入れ鋼 (SKD61, DAC材) 硬さ40-50HRC Hardened steel (1.2344) 40-50HRC	JC8015 (肉盛り加工用-MOW形 使用のこと (Recommend to use -MOW type insert)	n (min ⁻¹)	1,200	1,200	1,200	—
		V_f (mm/min)	420	540	400	—
		a_p (mm)	~6	~5	~8	—
		a_e (mm)	—	6	10	—
肉盛り材・焼入れ鋼 (SKD11) 硬さ55-63HRC Welding & Hardened steel (1.2379) 55-63HRC	JC8015 (肉盛り加工用-MOW形 使用のこと (Recommend to use -MOW type insert)	n (min ⁻¹)	1,200	1,200	—	—
		V_f (mm/min)	360	400	—	—
		a_p (mm)	~3	~3	—	—
		a_e (mm)	—	6	—	—
ねずみ鋳鉄 (FC250) 硬さ160-260HB Cast iron (GG25) 160-260HB	JC8015	n (min ⁻¹)	1,500	1,500	1,500	1,200
		V_f (mm/min)	970	1,400	900	480
		a_p (mm)	15	10	25	40
		a_e (mm)	—	10	15	10
ダクタイル鋳鉄、合金鋳鉄 (FCD700, GM241) 硬さ170-300HB Nodular cast iron (GGG70) 170-300HB	JC8015	n (min ⁻¹)	1,300	1,300	1,300	1,050
		V_f (mm/min)	700	1,000	650	370
		a_p (mm)	15	10	25	40
		a_e (mm)	—	10	15	10

n : 工具回転速度, V_f : 送り速度, a_p : 切込み深さ, a_e : ピックフィード n : Spindle speed, V_f : Feed speed, a_p : Depth of cut, a_e : Pick feed

注) 1. 上記の切削条件は、機械剛性およびワーク剛性に応じて調整ください。
2. エアブロー(乾式)にてご利用ください。

Note) 1. The figures to be adjusted according to the machine rigidity or work rigidity.
2. Use air blow.

φ40mm スウィングボール標準切削条件表 Recommended cutting conditions for Swing Ball 40mm dia.

加工形態 Type of machining							
被削材 Materials	チップ材種 Grade	切削条件 Parameter	溝加工 Slotting	肩削り加工 Shoulder cutting		深い肩削り加工 Shoulder cutting	
中炭素鋼 (S50C, S55C) 硬さ150-250HB Medium carbon steel (C50, C55) 150-250HB	JC5040	n (min ⁻¹)	1,850	1,850	1,850	1,500	
		V_f (mm/min)	800	1,070	740	480	
		a_p (mm)	12	10	20	35	
		a_e (mm)	-	8	12	8	
鋳鋼 (GM190, ICD5) 硬さ150-285HB Cast steel (1.7225) 150-285HB	JC5040	n (min ⁻¹)	1,670	1,670	1,670	1,340	
	JC8015 (40HRC以上) (JC8015 above 40HRC)	V_f (mm/min)	720	960	670	420	
	a_p (mm)	12	10	20	35		
	a_e (mm)	-	8	12	8		
工具鋼 (SKD11, SX105V) 硬さ150-255HB Die steel (1.2379) 150-255HB	JC5040	n (min ⁻¹)	1,560	1,560	1,560	1,250	
		V_f (mm/min)	620	810	560	350	
		a_p (mm)	12	10	20	35	
		a_e (mm)	-	8	12	4	
焼入れ鋼 (SKD61, DAC材) 硬さ40-50HRC Hardened steel (1.2344) 40-50HRC	JC8015 (肉盛り加工用-M○W形 使用のこと (Recommend to use-M○W type insert)	n (min ⁻¹)	1,200	1,200	1,200	-	
		V_f (mm/min)	420	540	420	-	
		a_p (mm)	~5	~4	~6.5	-	
		a_e (mm)	-	5	8	-	
肉盛り材・焼入れ鋼 (SKD11) 硬さ55-63HRC Welding & Hardened steel (1.2379) 55-63HRC	JC8015 (肉盛り加工用-M○W形 使用のこと (Recommend to use-M○W type insert)	n (min ⁻¹)	1,000	1,000	-	-	
		V_f (mm/min)	300	350	-	-	
		a_p (mm)	~3	~3	-	-	
		a_e (mm)	-	5	-	-	
ねずみ鋳鉄 (FC250) 硬さ160-260HB Cast iron (GG25) 160-260HB	JC8015	n (min ⁻¹)	1,850	1,850	1,850	1,500	
		V_f (mm/min)	1,100	1,500	1,000	570	
		a_p (mm)	12	10	20	35	
		a_e (mm)	-	8	12	8	
ダクタイル鋳鉄・合金鋳鉄 (FCD700, GM241) 硬さ170-300HB Nodular cast iron (GGG70) 170-300HB	JC8015	n (min ⁻¹)	1,650	1,650	1,650	1,320	
		V_f (mm/min)	830	1,100	760	450	
		a_p (mm)	12	10	20	35	
		a_e (mm)	-	8	12	8	

n : 工具回転速度, V_f : 送り速度, a_p : 切込み深さ, a_e : ピックフィード n : Spindle speed, V_f : Feed speed, a_p : Depth of cut, a_e : Pick feed

注) 1. 上記の切削条件は、機械剛性およびワーク剛性に応じて調整ください。
2. エアブロー(乾式)にてご利用ください。

Note) 1. The figures to be adjusted according to the machine rigidity or work rigidity.
2. Use air blow.

φ30(φ32)mm スwingボール標準切削条件表 Recommended cutting conditions for Swing Ball 32mm dia. and 30mm dia.

加工形態 Type of machining						
被削材 Materials	チップ材種 Grade	切削条件 Parameter	溝加工 Slotting	肩削り加工 Shoulder cutting		深い肩削り加工 Shoulder cutting
中炭素鋼 (S50C, S55C) 硬さ150-250HB Medium carbon steel (C50, C55) 150-250HB	JC5040	n (min ⁻¹)	2,300	2,300	2,300	1,800
		V_f (mm/min)	800	1,020	770	450
		a_p (mm)	10	10	16	28
		a_e (mm)	—	6	9	6
鋳鋼 (GM190, ICD5) 硬さ150-285HB Cast steel (1.7225) 150-285HB	JC5040	n (min ⁻¹)	2,090	2,090	2,090	1,670
	JC8015 (40HRC以上) JC8015 (above 40HRC)	V_f (mm/min)	720	920	700	420
	a_p (mm)	10	10	16	28	
	a_e (mm)	—	6	9	6	
工具鋼 (SKD11, SX105V) 硬さ150-255HB Die steel (1.2379) 150-255HB	JC5040	n (min ⁻¹)	1,950	1,950	1,950	1,560
		V_f (mm/min)	630	810	600	390
		a_p (mm)	10	10	16	28
		a_e (mm)	—	6	9	3
焼入れ鋼 (SKD61, DAC材) 硬さ40-50HRC Hardened steel (1.2344) 40-50HRC	JC8015 (肉盛り加工用-MOW形 使用のこと (Recommend to use -MOW type insert)	n (min ⁻¹)	1,600	1,600	1,600	—
		V_f (mm/min)	400	480	400	—
		a_p (mm)	~4	~4	~6.5	—
		a_e (mm)	—	5	8	—
肉盛り材・焼入れ鋼 (SKD11) 硬さ55-63HRC Welding & Hardened steel (1.2379) 55-63HRC	JC8015 (肉盛り加工用-MOW形 使用のこと (Recommend to use -MOW type insert)	n (min ⁻¹)	1,400	1,400	—	—
		V_f (mm/min)	280	350	—	—
		a_p (mm)	~3	~3	—	—
		a_e (mm)	—	5	—	—
ねずみ鋳鉄 (FC250) 硬さ160-260HB Cast iron (GG25) 160-260HB	JC8015	n (min ⁻¹)	2,300	2,300	2,300	1,840
		V_f (mm/min)	1,140	1,380	1,020	640
		a_p (mm)	10	10	16	28
		a_e (mm)	—	6	9	6
ダクタイル鋳鉄、合金鋳鉄 (FCD700, GM241) 硬さ170-300HB Nodular cast iron (GGG70) 170-300HB	JC8015	n (min ⁻¹)	2,060	2,060	2,060	1,650
		V_f (mm/min)	890	1,130	820	500
		a_p (mm)	10	10	16	28
		a_e (mm)	—	6	9	6

n : 工具回転速度, V_f : 送り速度, a_p : 切込み深さ, a_e : ピックフィード n : Spindle speed, V_f : Feed speed, a_p : Depth of cut, a_e : Pick feed

注) 1. 上記の切削条件は、機械剛性およびワーク剛性に応じて調整ください。
2. エアブロー(乾式)にてご利用ください。

Note) 1. The figures to be adjusted according to the machine rigidity or work rigidity.
2. Use air blow.

φ25mm スウィングボール標準切削条件表 Recommended cutting conditions for Swing Ball 25mm dia.

加工形態 Type of machining							
被削材 Materials	チップ材種 Grade	切削条件 Parameter	溝加工 Slotting	肩削り加工 Shoulder cutting		深い肩削り加工 Shoulder cutting	
中炭素鋼 (S50C, S55C) 硬さ150-250HB Medium carbon steel (C50, C55) 150-250HB	JC5040	n (min ⁻¹)	2,550	2,550	2,550	2,290	
		V_f (mm/min)	760	890	690	500	
		a_p (mm)	6	6	12.5	20	
		a_e (mm)	-	5	6.5	3	
鋳鋼 (GM190, ICD5) 硬さ150-285HB Cast steel (1.7225) 150-285HB	JC5040	n (min ⁻¹)	2,400	2,400	2,400	2,160	
	JC8015 (40HRC以上) (JC8015 above 40HRC)	V_f (mm/min)	720	840	640	480	
	a_p (mm)	6	6	12.5	20		
	a_e (mm)	-	5	6.5	3		
工具鋼 (SKD11, SX105V) 硬さ150-255HB Die steel (1.2379) 150-255HB	JC5040	n (min ⁻¹)	2,160	2,160	2,160	1,910	
		V_f (mm/min)	590	690	540	420	
		a_p (mm)	6	6	12.5	20	
		a_e (mm)	-	5	6.5	3	
焼入れ鋼 (SKD61, DAC材) 硬さ40-50HRC Hardened steel (1.2344) 40-50HRC	JC8015 (肉盛り加工用-M○W形 使用のこと (Recommend to use-M○W type insert)	n (min ⁻¹)	1,600	1,600	1,600	-	
		V_f (mm/min)	350	400	350	-	
		a_p (mm)	~3	~3	~5	-	
		a_e (mm)	-	4	5	-	
肉盛り材・焼入れ鋼 (SKD11) 硬さ55-63HRC Welding & Hardened steel (1.2379) 55-63HRC	JC8015 (肉盛り加工用-M○W形 使用のこと (Recommend to use-M○W type insert)	n (min ⁻¹)	1,400	1,400	-	-	
		V_f (mm/min)	280	350	-	-	
		a_p (mm)	~2	~2	-	-	
		a_e (mm)	-	4	-	-	
ねずみ鋳鉄 (FC250) 硬さ160-260HB Cast iron (GG25) 160-260HB	JC8015	n (min ⁻¹)	2,550	2,550	2,550	2,290	
		V_f (mm/min)	1,000	1,150	900	650	
		a_p (mm)	6	6	12.5	20	
		a_e (mm)	-	5	6.5	3	
ダクタイル鋳鉄・合金鋳鉄 (FCD700, GM241) 硬さ170-300HB Nodular cast iron (GGG70) 170-300HB	JC8015	n (min ⁻¹)	2,400	2,400	2,400	2,160	
		V_f (mm/min)	860	1,000	770	600	
		a_p (mm)	6	6	12.5	20	
		a_e (mm)	-	5	6.5	3	

n : 工具回転速度, V_f : 送り速度, a_p : 切込み深さ, a_e : ピックフィード n : Spindle speed, V_f : Feed speed, a_p : Depth of cut, a_e : Pick feed

注) 1. 上記の切削条件は、機械剛性およびワーク剛性に応じて調整ください。 (Note) 1. The figures to be adjusted according to the machine rigidity or work rigidity.
2. エアブロー(乾式)にてご利用ください。 (2. Use air blow.)

スウィングボールの溝加工時のフォーム Machined form by Swing Ball

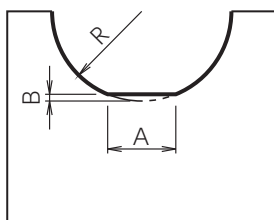

注) 先端部に上記のような形状誤差が生じます。
Note) Above form error can occur at center point.

●SWB形 SWB type

R	A	B
8	0.5	0.01
10	2.1	0.05
12.5	3.0	0.09
15	3.3	0.09
16	3.4	0.09
20	4.3	0.12
25	5.2	0.14

●SWB-H形(中仕上げ) SWB-H type for semi-finishing

R	A	B
10	0.6	0.01
12.5	0.7	0.01
15	0.9	0.01

φ20mm スwingボール標準切削条件表 Recommended cutting conditions for Swing Ball 20mm dia.

加工形態 Type of machining						
被削材 Materials	チップ材種 Grade	切削条件 Parameter	溝加工 Slotting	肩削り加工 Shoulder cutting		深い肩削り加工 Shoulder cutting
中炭素鋼 (S50C, S55C) 硬さ150-250HB Medium carbon steel (C50, C55) 150-250HB	JC5040	n (min ⁻¹)	3,180	3,180	3,180	2,860
		V_f (mm/min)	890	1,000	800	570
		a_p (mm)	5	5	10	16
		a_e (mm)	-	4	5	2
鋳鋼 (GM190, ICD5) 硬さ150-285HB Cast steel (1.7225) 150-285HB	JC5040 JC8015 (40HRC以上) JC8015 (above 40HRC)	n (min ⁻¹)	3,020	3,020	3,020	2,700
		V_f (mm/min)	820	920	760	540
		a_p (mm)	5	5	10	16
		a_e (mm)	-	4	5	2
工具鋼 (SKD11, SX105V) 硬さ150-255HB Die steel (1.2379) 150-255HB	JC5040	n (min ⁻¹)	2,700	2,700	2,700	2,390
		V_f (mm/min)	680	810	630	480
		a_p (mm)	5	5	10	16
		a_e (mm)	-	4	5	2
焼入れ鋼 (SKD61, DAC材) 硬さ40-50HRC Hardened steel (1.2344) 40-50HRC	JC8015 (肉盛り加工用-MOW形 使用のこと (Recommend to use -MOW type insert)	n (min ⁻¹)	1,750	1,750	1,750	-
		V_f (mm/min)	350	400	320	-
		a_p (mm)	~2	~2	~4	-
		a_e (mm)	-	3	4	-
肉盛り材・焼入れ鋼 (SKD11) 硬さ55-63HRC Welding & Hardened steel (1.2379) 55-63HRC	JC8015 (肉盛り加工用-MOW形 使用のこと (Recommend to use -MOW type insert)	n (min ⁻¹)	1,400	1,400	-	-
		V_f (mm/min)	280	350	-	-
		a_p (mm)	~1	~1	-	-
		a_e (mm)	-	3	-	-
ねずみ鋳鉄 (FC250) 硬さ160-260HB Cast iron (GG25) 160-260HB	JC8015	n (min ⁻¹)	3,180	3,180	3,180	2,860
		V_f (mm/min)	1,160	1,300	1,040	740
		a_p (mm)	5	5	10	16
		a_e (mm)	-	4	5	2
ダクタイル鋳鉄・合金鋳鉄 (FCD700, GM241) 硬さ170-300HB Nodular cast iron (GGG70) 170-300HB	JC8015	n (min ⁻¹)	3,020	3,020	3,020	2,700
		V_f (mm/min)	980	1,100	910	650
		a_p (mm)	5	5	10	16
		a_e (mm)	-	4	5	2

n : 工具回転速度, V_f : 送り速度, a_p : 切込み深さ, a_e : ピックフィード n : Spindle speed, V_f : Feed speed, a_p : Depth of cut, a_e : Pick feed

注) 1. 上記の切削条件は、機械剛性およびワーク剛性に応じて調整ください。 Note) 1. The figures to be adjusted according to the machine rigidity or work rigidity.
2. エアブロー(乾式)にてご利用ください。 2. Use air blow.

スwingボールプランジ加工時の最大突込み深さおよび送り Maximum plunging depth and feed rate for Swing Ball

被削材 Materials	最大値 Max. value	工具径 Tool dia.: ϕD_C (mm)				
		20	25	30, 32	40	50
鋳鉄 (FC, FCD, GM材) Cast iron (GG, GGG)	a_p (mm)	4	5	10	15	15
	f (mm/rev)	0.30	0.40	0.40	0.40	0.40
炭素鋼、合金鋼、工具鋼 Cast steel, Alloy steel, Die steel	a_p (mm)	3	4	8	10	10
	f (mm/rev)	0.25	0.30	0.30	0.30	0.30

a_p : 切込み深さ, f : 送り量 a_p : Depth of cut, f : feed

注) 中仕上げ用チップ使用時のプランジ加工は推奨しません。 Note) In case of using -H type insert (main blade for semi-finishing), plunging is not recommended.
やむをえず使用する場合は送り量を下げて使用ください。 But in case of working, recommend to reduce the feed.

φ16mm スwingボール標準切削条件表 Recommended cutting conditions for Swing Ball 16mm dia.

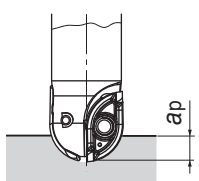
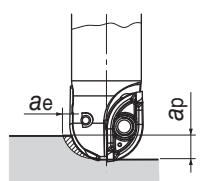
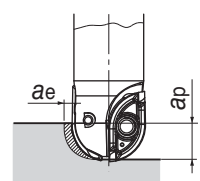
加工形態 Type of machining								
被削材 Materials	チップ材種 Grade	切削条件 Parameter	溝加工 Slotting					
			首下長 Overhung length					
			50mm	100mm	50mm	100mm	50mm	100mm
炭素鋼 (S50C, S55C) 硬さ250HB以下 Carbon steel (C50, C55) Below 250HB	JC8050 (JC5118)	n (min ⁻¹)	4,000	4,000	4,000	4,000	3,800	3,800
		V_f (mm/min)	560	560	1,000	800	570	460
		a_p (mm)	4	2	4	3	8	8
		a_e (mm)	—	—	5	3	4	2
鋳鋼 (GM190, ICD5) 硬さ285HB以下 Cast steel (1.7225) Below 285HB	JC5118	n (min ⁻¹)	3,800	3,800	3,800	3,800	3,600	3,600
		V_f (mm/min)	530	530	950	760	540	430
		a_p (mm)	4	2	4	3	8	8
		a_e (mm)	—	—	5	3	4	2
工具鋼 (SKD61, SKD11) 硬さ255HB以下 Die steel (1.2344, 1.2379) Below 255HB	JC8050 (JC5118)	n (min ⁻¹)	3,800	3,800	3,800	3,800	3,600	3,600
		V_f (mm/min)	530	530	570	460	470	430
		a_p (mm)	4	2	4	3	8	8
		a_e (mm)	—	—	5	3	4	2
焼入れ鋼 (SKD61, DAC, DHA) 硬さ40-50HRC Hardened die steel (1.2344, 1.2379) 40-50HRC	JC5118	n (min ⁻¹)	2,200	2,200	2,200	2,200	2,000	2,000
		V_f (mm/min)	260	260	260	260	240	240
		a_p (mm)	2	1	2	1	6	4
		a_e (mm)	—	—	2	1	1	1
焼入れ鋼 (SKD61, DAC, DHA) 硬さ50-60HRC Hardened die steel (1.2344, 1.2379) 50-60HRC	JC5118	n (min ⁻¹)	1,200	1,200	1,200	1,200	1,000	1,000
		V_f (mm/min)	150	120	140	140	120	120
		a_p (mm)	1	1	2	1	6	4
		a_e (mm)	—	—	2	1	1	1
鋳鉄 (FC, FCD) 硬さ300HB以下 Grey & Nodular cast iron (GG, GGG) Below 300HB	JC5118	n (min ⁻¹)	3,800	3,800	3,800	3,800	3,600	3,600
		V_f (mm/min)	760	760	1,400	1,100	1,300	1,100
		a_p (mm)	4	2	4	3	8	8
		a_e (mm)	—	—	6	3	4	2
プリハードン鋼 (HPM7, PX5, NAK80, P20) 硬さ30-43HRC Mold steel (1.2311, P20) 30-43HRC	JC8050 (JC5118)	n (min ⁻¹)	3,400	3,400	3,400	3,400	3,200	3,200
		V_f (mm/min)	480	480	510	400	380	380
		a_p (mm)	4	2	4	3	8	8
		a_e (mm)	—	—	5	3	4	2
ステンレス鋼 (SUS304) 硬さ250HB以下 Stainless steel Below 250HB	JC8050 (JC5118)	n (min ⁻¹)	3,800	3,800	3,800	3,800	3,600	3,600
		V_f (mm/min)	530	530	570	460	470	430
		a_p (mm)	4	2	4	3	8	8
		a_e (mm)	—	—	5	3	4	2

n : 工具回転速度, V_f : 送り速度, a_p : 切込み深さ, a_e : ピックフィード n : Spindle speed, V_f : Feed speed, a_p : Depth of cut, a_e : Pick feed

注) 1. 上記の切削条件は、機械剛性およびワーク剛性に応じて調整ください。 Note) 1. The figures to be adjusted according to the machine rigidity or work rigidity.
2. エアブロー(乾式)にてご利用ください。 2. Use air blow.

スイングボールの溝加工時のフォーム

Machined form by Swing Ball

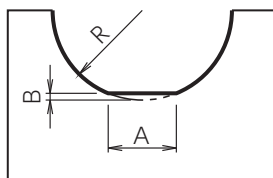

●SWB形 SWB type

R	A	B
8	0.5	0.01

注) 先端部に上図のような形状誤差が生じます。 Note) Above form error can occur at center point.



スウィングボール モジュラーヘッド 標準切削条件

Recommended cutting conditions for MSW and MSN

モジュラーヘッドMSW形 + 頑固一徹 (モジュラーヘッド用オール超硬シャンクアーバ)

被削材 Work materials	チップ 材種 Grades	工具径(mm) Tool dia.				
		16				
		刃数 No. of teeth 2N				
		ℓ (mm)	a_p (mm)	a_e (mm)	n (min ⁻¹)	V_f (mm/min)
炭素鋼 (S50C, S55C) 硬さ250HB以下 Carbon steel (C50, C55) Below 250HB	JC5118 (JC8050)	50	1.1	1	4,200	2,900
		100	0.7	0.7	4,200	2,900
		150	0.3	0.3	3,600	2,520
鋳鋼 (GM190, ICD5) 硬さ285HB以下 Cast steel (1.7225) Below 285HB	JC5118	50	1.1	1	4,000	2,800
		100	0.7	0.7	4,000	2,800
		150	0.3	0.3	3,400	2,380
工具鋼 (SKD61, SKD11) 硬さ255HB以下 Die steel (1.2344, 1.2379) Below 255HB	JC5118 (JC8050)	50	1.1	1	4,000	2,800
		100	0.7	0.7	4,000	2,800
		150	0.3	0.3	3,400	2,400
焼入れ鋼 (SKD61, DAC, DHA) 硬さ40-50HRC Hardened die steel (1.2344, 1.2379) 40-50HRC	JC5118	50	1	1	2,400	1,200
		100	0.6	0.6	2,000	1,000
		150	0.2	0.2	1,200	600
肉盛り材・焼入れ鋼 (SKD11) 硬さ55-62HRC Hardened die steel (1.2379) 55-62HRC	JC5118	50	0.5	0.5	1,800	700
		100	0.3	0.3	1,600	650
		150	—	—	—	—
鋳鉄 (FC, FCD) 硬さ300HB以下 Grey & Nodular cast iron (GG, GGG) Below 300HB	JC5118	50	1.3	1.3	4,000	2,800
		100	1.2	1	4,000	2,800
		150	0.7	0.5	3,400	2,400
プリハードン鋼 (HPM7, PX5, NAK80, P20) 硬さ30-43HRC Mold steel (1.2311, P20) 30-43HRC	JC5118 (JC8050)	50	1.1	1	3,600	2,100
		100	0.7	0.7	3,600	2,100
		150	0.3	0.3	3,000	1,800
ステンレス鋼 (SUS304) 硬さ250HB以下 Stainless steel Below 250HB	JC8050 (JC5118)	50	1.1	1	4,000	2,800
		100	0.7	0.7	4,000	2,800
		150	0.3	0.3	3,400	2,400

ℓ : エンドミル突出し長さ, a_p : 切込み深さ, a_e : ピックフィード, n : 工具回転速度, V_f : 送り速度

ℓ : Overhung length, a_p : Depth of cut, a_e : Pick feed, n : Spindle speed, V_f : Feed speed

■使用上の注意事項

- 1) 上記の切削条件は、機械剛性およびワーク剛性に応じて調整ください。
- 2) びびりが発生した場合は、切込み深さを上記数値よりも浅くしてください、あるいは回転速度を下げてください。
- 3) 突出しが短い場合は、最大切込み量 $a_p \times a_e = 3$ まで使用可能です (焼入れ鋼は除く)。
ただし、送り速度 V_f は機械剛性およびワーク剛性に応じて下げてください。

NOTE

- 1) The figure to be adjusted according to the machine rigidity or work rigidity.
- 2) In case of chatter occurring, recommend to reduce the depth of cut a_p or Spindle speed and keep feed per tooth.
- 3) In case of short overhung, maximum a_p can apply 3mm except hardened steel. But please adjust V_f according to machine and work rigidity.



スウィングボール モジュラーヘッド 標準切削条件

Recommended cutting conditions for MSW and MSN

モジュラーヘッドMSW形 + 頑固一徹(モジュラーヘッド用オール超硬シャンクアーバ)

被削材 Work materials	チップ材種 Grades	工具径(mm) Tool dia.														
		20					25					30 / 32				
		刃数 No. of teeth 2N					刃数 No. of teeth 2N					刃数 No. of teeth 2N				
		ℓ (mm)	a_p (mm)	a_e (mm)	n (min ⁻¹)	V_f (mm/min)	ℓ (mm)	a_p (mm)	a_e (mm)	n (min ⁻¹)	V_f (mm/min)	ℓ (mm)	a_p (mm)	a_e (mm)	n (min ⁻¹)	V_f (mm/min)
炭素鋼 (S50C, S55C) 硬さ250HB以下 Carbon steel (C50, C55) Below 250HB	JC5040	70	1.3	1.3	4,800	3,360	90	1.3	1.3	3,800	2,700	100	1.5	1.5	3,000	2,100
		120	0.8	0.8	4,800	3,360	140	0.8	0.8	3,800	2,700	150	1.0	1.0	3,000	2,100
		190	0.3	0.4	4,000	2,800	210	0.3	0.5	3,200	2,200	210	0.3	0.7	2,650	1,860
鋳鋼 (GM190, ICD5) 硬さ285HB以下 Cast steel (1.7225) Below 285HB	JC5040	70	1.3	1.3	4,000	2,800	90	1.3	1.3	3,200	2,240	100	1.5	1.5	2,600	1,820
	JC8015 (40HRC以上) JC8015 (above 40HRC)	120	0.8	0.8	4,000	2,800	140	0.8	0.8	3,200	2,240	150	1.0	1.0	2,600	1,820
	190	0.3	0.4	3,600	2,500	210	0.3	0.5	2,800	1,960	210	0.3	0.7	2,300	1,600	
工具鋼 (SKD61, SX105V) 硬さ255HB以下 Die steel (1.2379) Below 255HB	JC5040	70	1.3	1.3	4,000	2,800	90	1.3	1.3	3,200	2,240	100	1.5	1.5	2,600	1,820
		120	0.8	0.8	4,000	2,800	140	0.8	0.8	3,200	2,240	150	1.0	1.0	2,600	1,820
		190	0.3	0.4	3,600	2,500	210	0.3	0.5	2,800	1,960	210	0.3	0.7	2,300	1,600
焼入れ鋼 (SKD61, DAC) 硬さ40-50HRC Hardened die steel (1.2344) 40-50HRC	JC8015	70	0.5	1.0	3,000	1,500	90	0.5	1.0	2,500	1,250	100	0.8	0.8	2,000	1,000
	肉盛り加工用 -M \odot W形 使用のこと Recommend to use -M \odot W type insert	120	0.3	0.4	2,500	1,250	140	0.3	0.5	2,000	1,000	150	0.5	0.7	1,800	900
	190	-	-	-	-	210	-	-	-	-	210	0.2	0.7	1,600	800	
肉盛り材・焼入れ鋼 (SKD11) 硬さ55-62HRC Hardened die steel (1.2379) 55-62HRC	JC8015	70	0.5	0.5	2,300	920	90	0.5	0.7	1,900	760	100	0.6	0.8	1,600	720
	肉盛り加工用 -M \odot W形 使用のこと Recommend to use -M \odot W type insert	120	0.3	0.4	2,000	800	140	0.3	0.5	1,600	640	150	0.3	0.7	1,300	590
	190	-	-	-	-	210	-	-	-	-	210	-	-	-	-	
鋳鉄 (FC, FCD) 硬さ300HB以下 Grey & Nodular cast iron (GG, GGG) Below 300HB	JC8015	70	1.5	1.5	4,000	3,200	90	1.5	1.5	3,200	2,560	100	1.5	1.5	2,600	2,100
		120	1.0	1.0	4,000	3,200	140	1.0	1.0	3,200	2,560	150	1.0	1.0	2,600	2,100
		190	0.3	0.4	3,600	2,900	210	0.3	0.5	2,800	2,240	210	0.3	0.7	2,300	1,800

ℓ : エンドミル突出し長さ, a_p : 切込み深さ, a_e : ピックフィード, n : 工具回転速度, V_f : 送り速度

ℓ : Overhung length, a_p : Depth of cut, a_e : Pick feed, n : Spindle speed, V_f : Feed speed

■使用上の注意事項

- 1) 上記の切削条件は、機械剛性およびワーク剛性に応じて調整ください。
- 2) びびりが発生した場合は、切込み深さを上記数値よりも浅くしてください、あるいは回転速度を下げてください。

NOTE

- 1) The figure to be adjusted according to the machine rigidity or work rigidity.
- 2) In case of chatter occurring, recommend to reduce the depth of cut a_p or Spindle speed and keep feed per tooth.



スウィングボールの溝加工時のフォーム

Machined form by Swing Ball

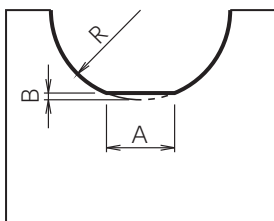

注) 先端部に上図のような形状誤差が生じます。
Note) Above form error can occur at center point.

●SWB形 SWB type

R	A	B
8	0.5	0.01
10	2.1	0.05
12.5	3.0	0.09
15	3.3	0.09
16	3.4	0.09

●SWB-H形(中仕上げ) SWB-H type for semi-finishing

R	A	B
10	0.6	0.01
12.5	0.7	0.01
15	0.9	0.01

SWE形 スウィングボール・エコ "Swing Ball ECO" SWE type



1. 経済的な3コーナ使用M級チップを採用。
2. 三次元ポジティブブレイカを採用により低切削抵抗を実現。
3. 低剛性工作機械の性能を最大限に引き出す事が可能。

1. Economy insert with 3 corners.
2. 3D inserts geometry gives low cutting forces.
3. Bring out the maximum performance for lower rigid machine.



DIN 規格 DIN standard

SWE-W type (ウェルドンシャック) (Weldon shank)

SWE-MT type (モールステーパシャック) (Morse taper shank)

SWE-C type (コンビネーションシャック) (Combination shank)

SWE-S type (ストレートシャック) (Straight shank)

Fig.1 (ウェルドンシャック Weldon shank)

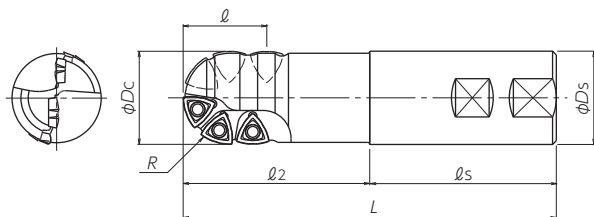

Fig.3 (コンビネーションシャック Combination shank)

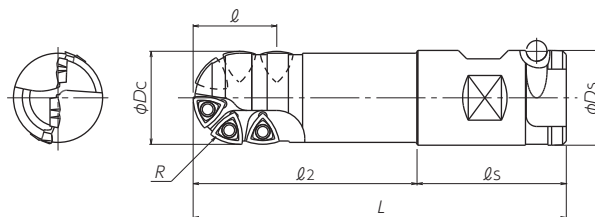

Fig.2 (モールステーパシャック Morse taper shank)

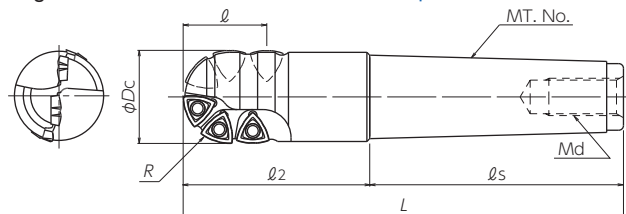
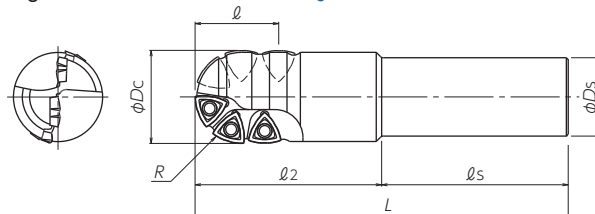

Fig.4 (ストレートシャック Straight shank)



■本体 Body

形番 Cat. No.	在庫 Stock	使用 チップ数 No. of inserts	寸法(mm) Dimensions								チップ Insert	クランプねじ Clamp screw	レンチ Wrench	Fig.				
			R	φDc	ℓ	ℓ2	ℓs	L	φDs	Md								
SWES5045S42	●					100	100	200										
SWEM5045S42	●	6	25	50	45	100	150	250	42	—	SWE350MB/ MS/ MW	DSW-511H	A-20	4				
SWEL5045S42	●					150	150	300										
SWEE5045S42	●					150	200	350										
SWES5045C508	●				120	80	200											
SWEM5045C508	●	6	25	50	45	170	80	250	50.8	—								
SWEL5045C508	●					220	80	300										
SWEE5045C508	●					270	80	350										
SWE-50120-MT5	●	6	25	50	45	120	136	256	MT5	M20×2.5					SWE350MB/ MS/ MW	DSW-511H	A-20	2
SWE-50170-MT5	●					170	136	306										
SWE-50100-W50	●	6	25	50	45	100	100	200	W50	—								
SWE-50150-W50	●					150	100	250										

注) 本体にチップは組込んでありません。

Note) All cutters are supplied without inserts.

切削条件 Cutting conditions 32ページ

クランプねじ形番
 Clamp screw
 DSW-511H
 推奨トルク(N・m)
 Recommended torque
 6.1

スウィングボール・エコ対応チップ

Inserts for "SWING BALL ECO"

低抵抗形 Low-resistance type

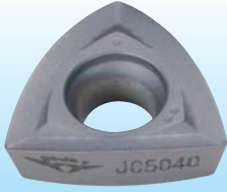

SWE350MB	PVDコーティング PVD coated
	JC5040

刃先強化形 Stronger edge type

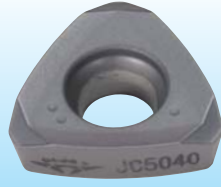

SWE350MS	PVDコーティング PVD coated
	JC5040

肉盛り用 For welding type

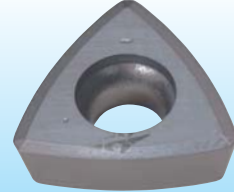

SWE350MW	PVDコーティング PVD coated
	JC5118

スウィングボール・エコの加工事例

Cutting data for "SWING BALL ECO"

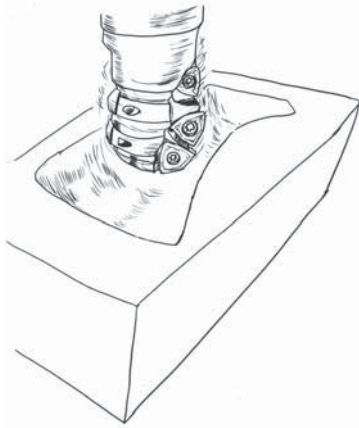

結果 Result

他社製に比べて切削抵抗、寿命とも良好。
Improved cutting resistance and tool life than competitor.

被加工材料 Work	名称 Part name	ヒートガード用金型 Mold for heat guard
	被削材 Material	FC250
	硬さ Hardness	-
使用工具 Tool	形番 Tool No.	SWES5045C508
	チップ形番、材種 Insert No.	SWE350MB(JC5040)
加工条件 Cutting conditions	切削速度、回転速度 $V_c, (n)$	204 m/min, (1,300 min ⁻¹)
	送り速度 V_f	600 mm/min
	a_p	15 mm
	a_e	10 mm
	クーラント Coolant	乾式 Dry cut
	使用機械 Machine	門形MC MC

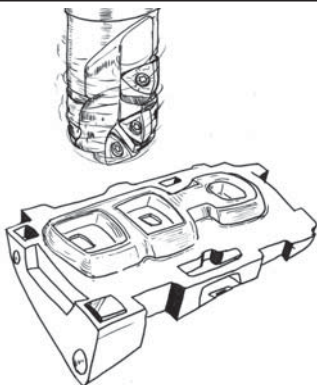

結果 Result

他社製に比べて切削抵抗が非常に小さく、分断された良い切り粉が出る。寿命2倍アップ。低剛性機械でも使用可能。
Showed much lower cutting resistance than competitor and good breaking chips. Improved tool life two times. Possible to use on lower rigid machine.

被加工材料 Work	名称 Part name	インナー部品用金型 Stamping die for inner parts
	被削材 Material	HMD5
	硬さ Hardness	-
使用工具 Tool	形番 Tool No.	SWES5045C508
	チップ形番、材種 Insert No.	SWE350MB(JC5040)
加工条件 Cutting conditions	切削速度、回転速度 $V_c, (n)$	204 m/min, (1,300 min ⁻¹)
	送り速度 V_f	600 mm/min
	a_p	10 mm
	a_e	10 mm
	クーラント Coolant	乾式 Dry cut
	使用機械 Machine	門形MC MC

φ50mm スwingボール・エコ標準切削条件表 Recommended cutting conditions for Swing Ball Eco 50mm dia.

加工形態 Type of machining					
被削材 Materials	チップ材種 Grade	切削条件 Parameter	溝加工 Slotting	肩削り加工 Shoulder cutting	
中炭素鋼 (S50C, S55C) 硬さ150-250HB Medium carbon steel (C50, C55) 150-250HB	SWE350MB SWE350MS JC5040	n (min ⁻¹)	1,500	1,500	1,500
		V_f (mm/min)	360	500	300
		a_p (mm)	15	10	25
		a_e (mm)	—	10	10
鋳鋼 (GM190, ICD5) 硬さ150-285HB Cast steel (1.7225) 150-285HB	SWE350MB SWE350MS JC5040	n (min ⁻¹)	1,350	1,350	1,350
		V_f (mm/min)	325	450	300
		a_p (mm)	15	10	25
		a_e (mm)	—	10	10
工具鋼 (SKD11, SX105V) 硬さ150-255HB Die steel (1.2379) 150-255HB	SWE350MB SWE350MS JC5040	n (min ⁻¹)	1,000	1,000	1,000
		V_f (mm/min)	250	300	200
		a_p (mm)	15	10	25
		a_e (mm)	—	10	10
焼入れ鋼 (SKD61, DAC材) 硬さ40-50HRC Hardened steel (1.2344) 40-50HRC	SWE350MW JC5015 SWE350MS JC5040	n (min ⁻¹)	1,000	1,000	1,000
		V_f (mm/min)	150	200	150
		a_p (mm)	~6	~5	~8
		a_e (mm)	—	6	~8
肉盛り材・焼入れ鋼 (SKD11) 硬さ55-63HRC Welding & Hardened steel (1.2379) 55-63HRC	SWE350MW JC5118	n (min ⁻¹)	1,000	1,000	—
		V_f (mm/min)	130	150	—
		a_p (mm)	~5	~3	—
		a_e (mm)	—	5	—
ねずみ鋳鉄 (FC250) 硬さ160-260HB Cast iron (GG25) 160-260HB	SWE350MB SWE350MS JC5040	n (min ⁻¹)	1,500	1,500	1,500
		V_f (mm/min)	420	600	400
		a_p (mm)	15	10	25
		a_e (mm)	—	10	10
ダクタイル鋳鉄、合金鋳鉄 (FCD700, GM241) 硬さ170-300HB Nodular cast iron (GGG70) 170-300HB	SWE350MB SWE350MS JC5040	n (min ⁻¹)	1,300	1,300	1,300
		V_f (mm/min)	300	430	280
		a_p (mm)	15	10	25
		a_e (mm)	—	10	10

n : 工具回転速度, V_f : 送り速度, a_p : 切込み深さ, a_e : ピックフィード n : Spindle speed, V_f : Feed speed, a_p : Depth of cut, a_e : Pick feed

注) 1. 上記の切削条件は、機械剛性およびワーク剛性に応じて調整ください。
2. エアブロー(乾式)にてご利用ください。

Note) 1. The figures to be adjusted according to the machine rigidity or work rigidity.
2. Use air blow.

Memo

A series of horizontal dashed lines for writing.



大阪事業所 (合金・工具工場) **Osaka plant**

超硬素材・切削工具・耐摩耗工具を生産する
ダイジェットの中核工場



三重原料工場 **Mie powder plant**

防災・安全衛生・品質面を大幅に向上させた
最新鋭の原料工場



三重合金工場 **Mie carbide plant**

隣接する刃先交換工具一貫生産工場などへ
素材を供給



三重工具工場 **Mie tool plant**

最新鋭の機械設備と効率的な生産ラインを備え、
ダイジェットの主力製品である高品質の
刃先交換工具を生産



富田林工場 (原料・合金) **Tondabayashi plant**

原料粉末調製の専門工場

ダイジェットが築く、 技術と信頼のネットワーク



Break Through

インターネットホームページ

<http://www.dijet.co.jp>

技術相談フリーコール

サンキュー ハイ サンキュー
0120-39-81-39

営業企画課
FAX 06-6793-1230

**ダイジェット工業株式会社****DIJET INDUSTRIAL CO., LTD.**

本社 〒547-0002 大阪市平野区加美東2丁目1番18号 TEL. 06(6791)6781代表 FAX. 06(6793)1221
 Headquarters 2-1-18, Kami-Higashi, Hirano-ku, Osaka 547-0002, Japan Phone: 81-6-6791-6781 Fax: 81-6-6793-1221

**国内拠点****東京支店 (東関東営業所)**

〒341-0034 埼玉県三郷市新和1丁目9番地 Residencia 善 1F
 TEL. 048(949)7720 FAX. 048(949)7730

南関東営業所

〒221-0835 神奈川県横浜市神奈川区鶴屋町2丁目26番地4 第3安田ビル5F
 TEL. 045(290)5100 FAX. 045(312)0066

北関東営業所

〒373-0818 群馬県太田市小舞木町614番地
 TEL. 0276(45)8588 FAX. 0276(46)7446

仙台オフィス

〒983-0852 仙台市宮城野区榴岡5丁目2番3号
 TEL. 022(299)0528 FAX. 022(299)3270

名古屋支店 (名古屋営業所)

〒466-0034 名古屋市昭和区明月町1丁目39番地2 エクセル御器所1F
 TEL. 052(851)5500 FAX. 052(851)8311

三河営業所

〒446-0058 愛知県安城市三河安城南町1丁目15番地10 シティタワー8F
 TEL. 0566(71)0505 FAX. 0566(74)3717

浜松オフィス

〒430-0926 静岡県浜松市中区砂山町340番地の7
 TEL. 053(456)2133 FAX. 053(456)7938

大阪支店 (大阪営業所)

〒547-0002 大阪市平野区加美東2丁目1番18号
 TEL. 06(6794)0216 FAX. 06(6794)0217

富山営業所

〒939-8096 富山市西大泉17番20号 浜忠第二ビル1-B
 TEL. 076(425)5171 FAX. 076(425)5187

広島営業所

〒734-0022 広島市南区東雲1丁目23番15号 板村ビル1F 103号
 TEL. 082(282)3712 FAX. 082(282)3742

九州営業所

〒812-0011 福岡市博多区博多駅前4丁目3番3号 博多八百治ビル5F
 TEL. 092(284)4610 FAX. 092(284)4617

工場

本社工場 〒547-0002 大阪市平野区加美東2丁目1番18号
 TEL. 06(6791)6781 FAX. 06(6793)1221

三重事業所 〒518-0205 三重県伊賀市伊勢路758-14
 TEL. 0595(52)2800 FAX. 0595(52)2841

富田林工場 〒584-0022 大阪府富田林市中野町東2丁目1番23号
 TEL. 0721(23)2700 FAX. 0721(23)2705

海外拠点**DIJET INDUSTRIAL CO., LTD. (Europe)**

Unit 2 Mundells Court, Welwyn Garden City, Herts AL7 1EN, England
 Phone. 44-1707-325444 Fax. 44-1707-330197

DIJET INDUSTRIAL CO., LTD. (Bangkok Representative Office)

699 Srinakarindr Road, Modernform Tower 15th Floor, Kweang Suanluang
 Khet Suanluang, Bangkok 10250, Thailand
 Phone. 66-2-722-8258, 8259 Fax. 66-2-722-8260

DIJET INDUSTRIAL CO., LTD. (Shanghai Representative Office)

Room No.1008 Tomson Commercial Building., 710 Dongfang Rd.,
 Shanghai 200122, China
 Phone. 86-21-5058-1698 Fax. 86-21-5058-1699

DIJET INDUSTRIAL CO., LTD. (Guandong Representative Office)

Rm. 1J2F, A Building, Lotus Plaza, Xianxidadao Road, Changan Town,
 Dongguan City, Guangdong Province, 523850 P. R., CHINA
 Phone. 86-769-8188-6001, 6002 Fax. 86-769-8188-6608

DIJET INDUSTRIAL CO., LTD. (Chengdu Office)

RM.No.2015, No.1BLDG.A-B Stand, Hi-Tech Incubation Garden, No.1480
 Tianfu Avenue North, Hi-Tech District, Chengdu City, Sichuan, P.R.CHINA
 Phone. 86-28-8511-4585 Fax. 86-28-8511-2758

DIJET INDUSTRIAL CO., LTD. (Wuhan Office)

Room A3117, Zhongshang office Bldg, No.7 Zhongnan Road, Wuchang,
 Wuhan City, Hubei, China
 Phone. 86-27-8773-8919 Fax. 86-27-8773-8959

DIJET INDUSTRIAL CO., LTD. (Mumbai Representative Office)

322, ARCADIA
 Hiranandani Estate, Patlipada, G.B. Road,
 Thane (W) 400 607, India
 Phone. 91-22-4012-1231 Fax. 91-22-4024-0919

DIJET Incorporated (U.S.A.)

45807 Helm Street, Plymouth, MI 48170 U.S.A.
 Phone. 1-734-454-9100 Fax. 1-734-454-9395

インターネットホームページ<http://www.dijet.co.jp>**技術相談フリーコール**サンキュー ハイ サンキュー
0120-39-81-39営業企画課
FAX 06-6793-1230**ご使用上の注意** 工具を安全にご使用いただくために

- 不適切な切削条件で使用しないでください。●大きな摩耗や欠けのある工具は使用しないでください。
- 切りくずの飛散、巻き付きによるケガにご注意ください。又、保護眼鏡や安全カバーをご使用ください。

WARNING: *Grinding produces hazardous dust. *To avoid adverse health, use adequate ventilation and read Material Safety Data Sheet first.
 *Cutting tools may fragment in use. Wear eye protection in the vicinity of their operation.

●工具仕様は、改良のため予告なく変更することがあります。 Specification shall be changed without notice.

販売店